

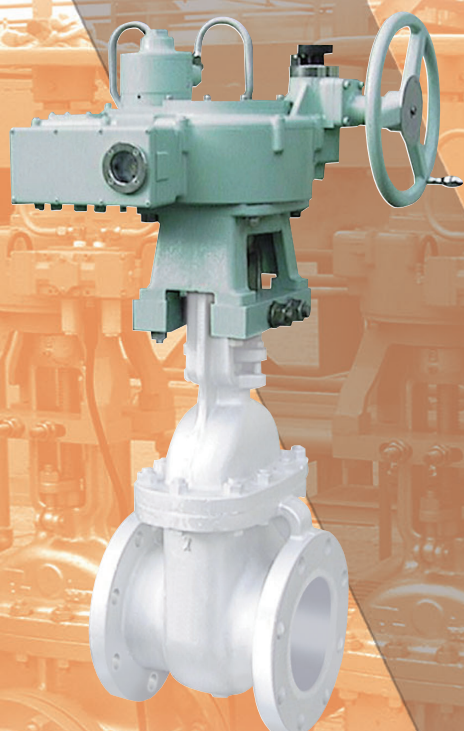

Most Suitable for Automating Existing Manual Valves

PNEUMATIC VALVE ACTUATOR

V-Torq II



Side handle type



Top handle type

Safe and
Reliable

Applicable valves ▶ ●Gate valve ●Globe valve ●Ball valve ●Butterfly valve, etc.

- Existing manual valves can easily be automated while being on the line.
- Most suitable to use as emergency shutoff valve (subject to the Fire Service Act).
- Existing manual valves can remotely be operated from the office.
- Even in a case of power failure, can be operated by securing air-supply.
- Work of automation and mounting are easy.
- By applying the mechanical torque-limiter, valves are not damaged.
- Help saving energy !
- Can easily be mounted in hazardous area (all pneumatic type).



Air switch box

V-Torq II

Features

1. An advanced, compact and lightweight valve actuator that readily mounts on an existing manual valve to retrofit it for automatic control. (Accommodates valves 2" to 40" in bore size, or larger.)
2. Constructed by plain gears treated with induction hardening process for virtually wear-free gear teeth, our proprietary torque limiter which serves to maintain consistent shutoff torque is a standard feature and safeguards the valve against damage by overtightening, while it ensures smooth opening and closing movement.
3. The air motor is of field proven vane type for quiet and smooth rotation.
4. A dedicated manual handle allows manual operation in case of emergency. (The manual handle remains locked in position to prevent movement during automatic operation, thus affording protection to the operator.)
5. Component parts are unitized to facilitate modification, maintenance and inspection.
6. With the addition of a potentiometer, a valve position indicator output is also available.

☆What is the torque limiter?

Our torque limiter is a mechanism designed for the purpose of closing the valve at consistent, proper torque. (Patented No. 1993887)
Using a spring-balance arrangement, it accurately detects valve's shutoff torque and, when a preset torque is reached, it stops the air motor.
The design therefore eliminates such complaints as valve overtightening or inoperative valve that has been shut off, characterized by most desirable performance for the valve with increased safety and service life.
Shutoff torque adjustment is also simple in the field.

Specifications

Item		Model	VTC-15 (Low torque type)	VTC-25 (High torque type)
Shutoff torque	N-m		40 to 250	150 to 400
Opening torque	N-m		400	600
No. of Open-Close Revolutions	rev		Set to 85 to 95% of total revolutions of target valve	
Supply air pressure	MPa		0.40 (0.35 to 0.70)	
Air Consumption	L/min (normal)		680	1100
Connection Dia.	Drive Tubing Rc		3/8	1/2
	Signal Tubing Rc		1/8	
Housing Material			Aluminum casting	
Finish			Munsell 7.5G7/2.5	
Operating Temperature Range			-10 to +60°C	
Weight	kg		27	29

Relationship of torque and rotational speed

Model	VTC-15 (Low torque type)		VTC-25 (High torque type)		
	A speed reduction	E speed reduction	A speed reduction	D speed reduction	E speed reduction
Shutoff Torque [N-m]	40 to 250	40 to 100	150 to 400	60 to 100	100 to 200
Open Torque [N-m]	400	200	600	200	400
Rotational Speed [rpm]	23	40	23	90	40

*The rotational speed indicated above is based on the supply air pressure of 0.4MPa supplied to the V-Torq II. Depending on the magnitude of load torque or individual product difference, the rotational speed may vary by about 10%.

Installation Procedures

■ Installation on top

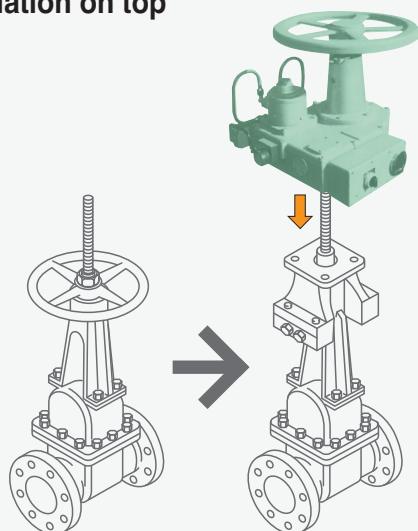

■ Installation on side

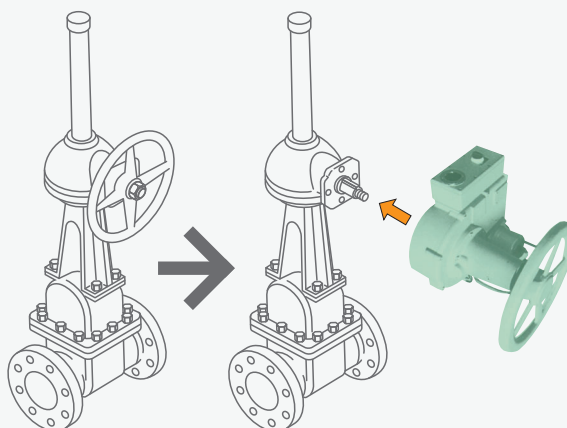

*: Most typical installation is shown here.

V-Torq II

● Outline Dimensions

φ A dimension: φ300 mm for 6B or less and
shutoff torque of 100N·m or less
φ360 mm if exceeding the above conditions

B dimension: 426 mm for VTC-15
444 mm for VTC-25

C dimension: 355 mm

* Becomes 10mm lower during manual operation.

D dimension: 120 mm for VTC-15
166 mm for VTC-25

* Only operation method type A is equipped with
Open/Stop/Close switch.

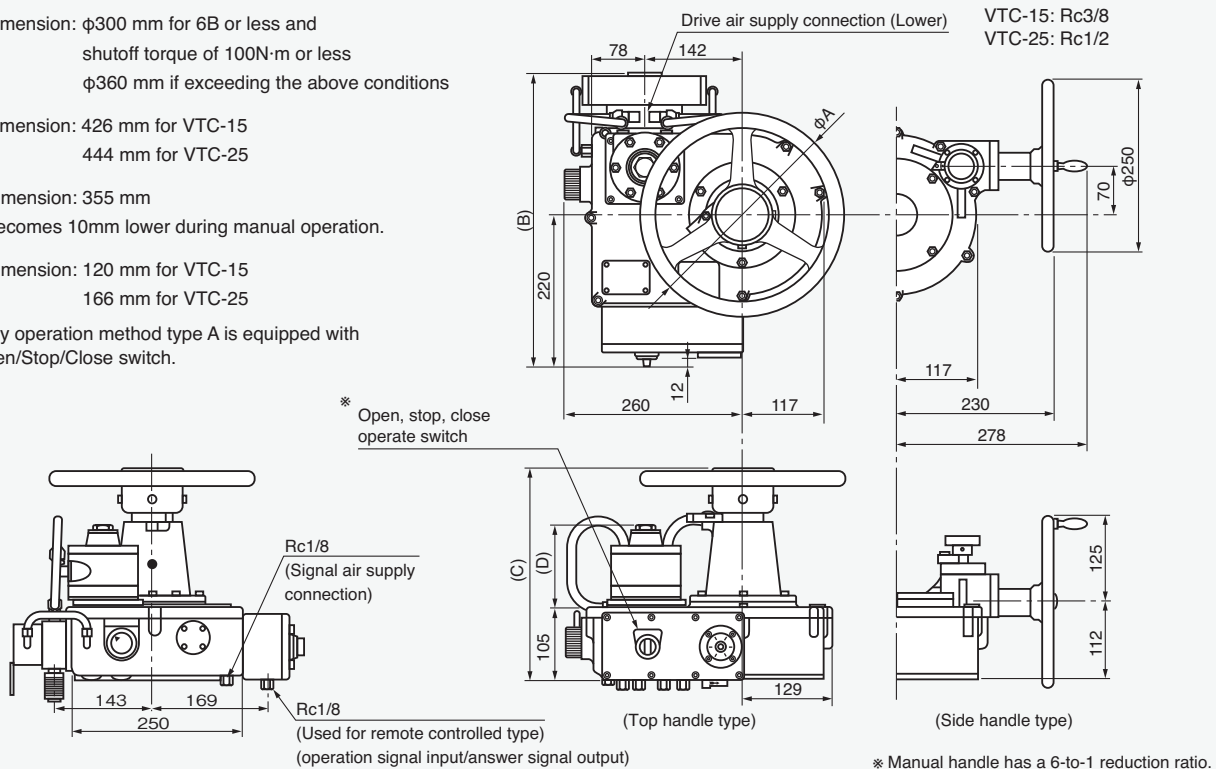

Operating Principle

■ All pneumatic type

Opens and closes the valve with the air switch box located remotely from V-Torq II. (Intermediate stop possible.)

- ◆ Two tubing for operate signals
Full close signal "1": Full close "0": Others
Full open signal "1": Full open "0": Others
(If intermediate stop is not required, single tubing suffices.)
- ◆ Two tubing for answerback signals
Full close signal "1": Full close "0": Others
Full open signal "1": Full open "0": Others
(If specified for full close or full open only, single tubing suffices.)
- ◆ With the addition of pressure switches, full close and full open indicators can be provided in the control room.

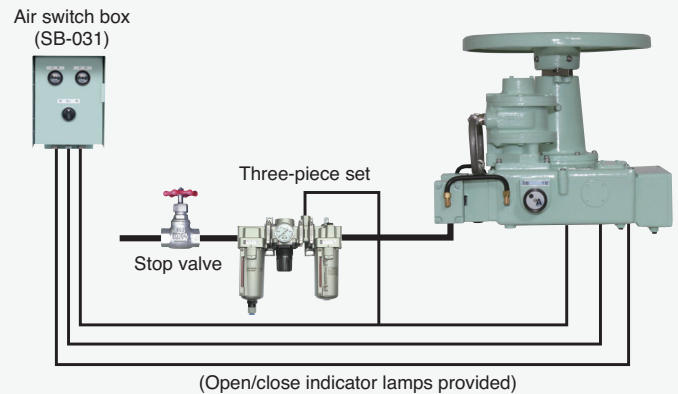

■ Remote control with solenoid valve type

Can control the entire system from control room or in the field by using a local/remote selector equipped air switch box with the addition of pressure switches and solenoid valves. (Intermediate stop possible.)

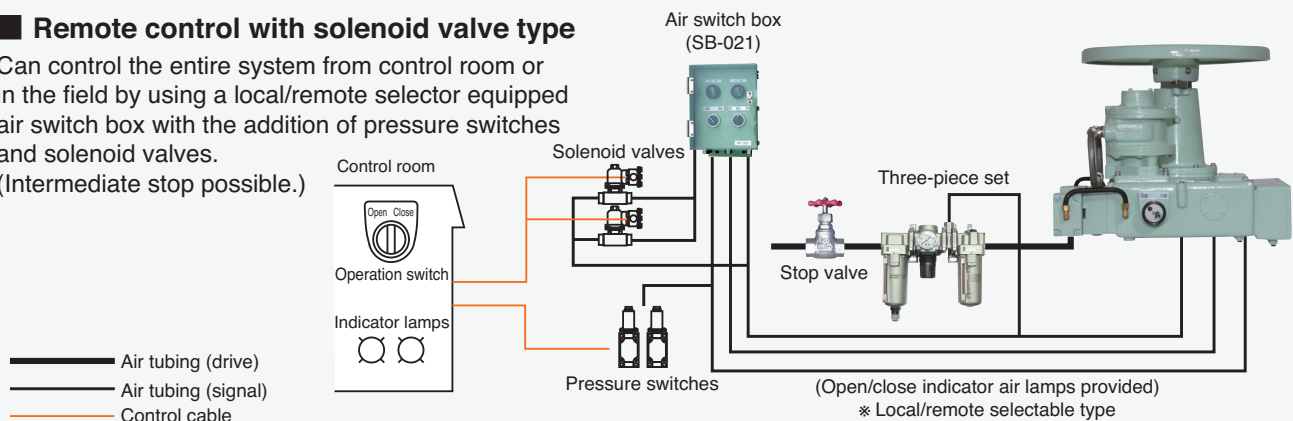

*: Examples of selectable operations are shown.

V-Torq II

Product Code Explanation

Item	Product code													Description				
	①	②	③	-	④	⑤	⑥	-	⑦	⑧	⑨	-	⑩		⑪	-	⑫	⑬
Model	V	T																Valve actuator
Type			C	-														V-Torq II
Air motor type					1	5												For low torque (4AM)
					2	5												For high torque (6AM)
Operating method (*1)							A	-										All pneumatic local type: the valve is opened/closed by the switch directly installed on body. (Intermediate stop possible)
							B	-										All pneumatic remote type: the valve is opened/closed via the air switch box.
							C	-										Remote control type (fully closed or fully open during power failure) The valve is opened/closed by operation of one solenoid valve. (Status signal: Intermediate stop not possible)
							E	-										Remote control type (hold during power failure) The valve is opened/closed by operation of two solenoid valves. (Status signal: Intermediate stop possible)
							H	-										Remote control type (hold during power failure) The valve is opened/closed by operation of two solenoid valves. (Pulse signal: Intermediate stop not possible)
							P	-										Operating method E + Valve opening signal (resistance value) output from potentiometer unit to control room
							Z	-										Special
Valve bore size							*	*										Indicated in inch (Ex.: 4B→04)
V-Torq II Manual handle type									T	-								Top handle
									S	-								Side handle
Indicator type										S								Standard (Dial type)
										O								option (Pointer type) (The number of revolutions cannot be changed.)
Speed reduction ratio									A	-								A reduction
									D	-								D reduction (Not selectable for VTC-15)
									E	-								E reduction
									Z	-								Special
External operating signal																		0 Not req'd (The switch on V-Torq II is used for opening/closing) Operation "A"
																		1 Close sig. only. Sig. "1": Valve close Sig. "0": Valve open Operation "B," "C"
																		2 Open sig. only. Sig. "1": Valve open Sig. "1": Valve open Operation "B," "C"
																		3 2 open/close input (status sig.) intermed. stop - Yes Operation "B," "E," "P"
																		4 2 open/close input (pulse sig. * 0.3s min.) intermed. stop - No Operation "B," "H"
External output signal																		9 Special
																		0 None
																		1 Full close signal only
																		2 Full open signal only
																		3 Full close, full open signal
																		4 Analog output (pot. output)
																	5 Analog output (pot. output) + full close, full open signal	
																	9 Special	

*1: In all operating methods, the answer signal (air signal) for fully open and fully closed can be output.
Electric signal when required is available via a (separately installed) pressure switch.

*2: If you have any question about analog output, contact us.

Installation Examples



☆Automated remote fire extinguishing equipment

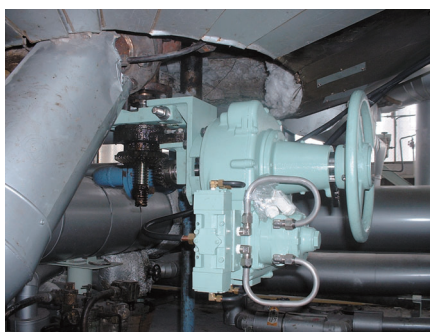

☆Automated reaction tank-bottom valve (special installation)



☆Automated marine shipping and receiving valves

The specification as of December, 2022 is stated in this catalog. Specifications and design are subject to change without notice.



OVAL Corporation

3-10-8 Kamiochiai, Shinjuku-ku, Tokyo 161-8508, Japan
Phone: 81-3-3360-5121 FAX: 81-3-3365-8605

<https://www.oval.co.jp/en/>

