



INSTRUCTIONS

Ins. No. S-179-6-E



ELECTRONICS REGISTER PROVIDED

FLOWPET-5G

Water service

MODEL : LS5277-5□□B, LS5377-5□□B, LS5577-5□□B, LS5677-5□□B

Oil service

MODEL : LS4976-5□□ $\begin{matrix} A \\ B \\ C \\ D \end{matrix}$, LS5076-5□□ $\begin{matrix} A \\ B \\ C \\ D \end{matrix}$, LS5276-5□□ $\begin{matrix} A \\ B \\ C \\ D \end{matrix}$, LS5376-5□□ $\begin{matrix} A \\ B \\ C \\ D \end{matrix}$, LS5576-5□□ $\begin{matrix} A \\ B \end{matrix}$, LS5676-5□□ $\begin{matrix} A \\ B \end{matrix}$

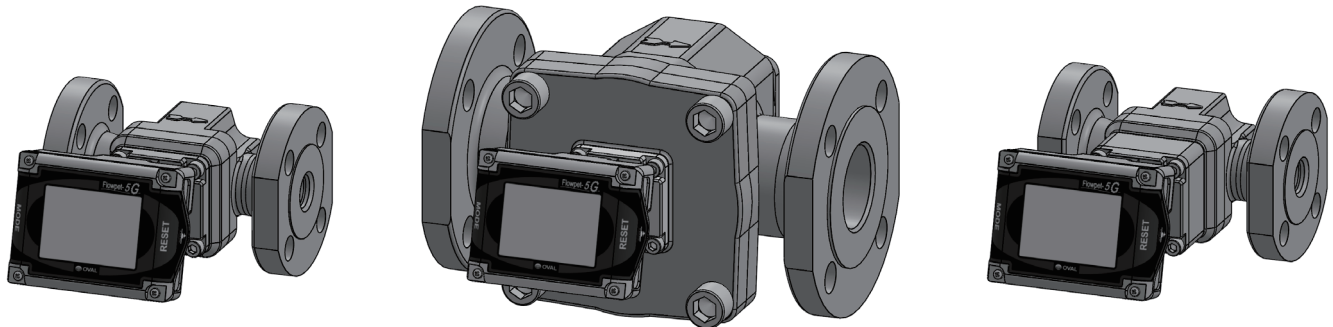

A great deal of time and care has been devoted to the proper designing, manufacturing and preparation of the **Flowpet-5G** for delivery into your hands. We hope that you derive from its operation the full measure of value and utility to which you looked forward to when you purchased it. Your considerate treatment and care will repay you well throughout its service life. **For these reasons, we suggest you to read this instruction manual thoroughly before use and keep it for your quick reference.**

CONTENTS

1. HANDLING PRECAUTIONS	7. OPERATION	26
1.1 Confirming the Nameplate.....	7.1 Operation.....	26
1.2 Transportation Precautions	7.2 About Register's Life	28
1.3 Storage Precautions.....	7.3 Battery Life.....	28
1.4 Installation Location Precautions.....	8. TROUBLESHOOTING	29
2. OPERATING CONDITIONS	9. DISASSEMBLY AND INSPECTION	32
3. GENERAL DESCRIPTION	10. EXPLODED VIEW AND SERVICE PARTS LIST	35
3.1 Features.....	Exploded View.....	35
3.2 Product Code Explanation.....	Service Part Lists	36
3.3 Part Names	11. BATTERY REPLACEMENT AND	
4. PIPING	PARAMETER SETTING PROCEDURE	37
4.1 Piping Precautions.....	11.1 Battery Replacement.....	37
4.2 Flushing the Piping Assembly.....	11.2 Parameter Setting Procedure	40
4.3 Lagging Work	12. GENERAL SPECIFICATIONS	50
4.4 Example of Installations.....	(1) Flow Range.....	50
4.5 How to Change the Flow Directions and	(2) Meter Body.....	50
Display Orientations.....	(3) Register, Pulse Generator	51
5. WIRING	(4) Units of Registration,Pulse Output Units of	
5.1 Field Wiring.....	Registration.....	52
5.2 Furnished Leads from the Meter.....	(5) Applicable standards.....	53
5.3 Hook-up Diagrams.....	13. OUTLINE DIMENSIONS	54
6. DISPLAY AND CONTROLS	(1) FLOWPET-5G.....	54
6.1 Display	(2) Strainer.....	55
6.2 Display Capabilities and Operation.....	14. KC mark	56

1. HANDLING PRECAUTIONS

Every unit is thoroughly tested and inspected before shipment from our factory. When received, its appearance should be inspected for possible damage by rough handling during transit. First of all, thoroughly read the handling precautions described in this section. For topics other than those stated in this section, refer to respective sections. If at any time in the future you seek our assistance, contact the nearest sales office in your area.

Shown in this manual are the signal words **NOTE**, **CAUTION** and **WARNING**, as described in the examples below:

 **NOTE:** Notes are separated from the general text to bring the user's attention to important information.

 **CAUTION:** Caution statements signal the user about hazards or unsafe practices which could result in minor personal injury or product or property damage.

 **WARNING:** Warning statements signal the user about hazards or unsafe practices which could result in severe personal injury or death.

1.1 Confirming the Nameplate

Each FLOWPET is adjusted to individual specifications before shipment from our factory. Indicated at the bottom of the register is the product code number and rated specification.

Make sure to see that Product Code Explanation in Section 3.2 and General Specifications in Section 12 conform to your particular specifications.

- **When you inquire, specify the product name, model number, serial number, ratings/specifications and other information.**

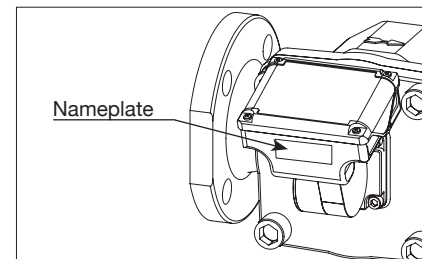

1.2 Transportation Precautions

- (1) In order to safeguard against damage during transportation, transport the instrument to the installation location in the style packaged from our factory if possible.
- (2) This instrument is adjusted and inspected as an assembly consisting of the flowmeter, pulse generator (sensor) and register. It should therefore be handled as an assembly at all times; you should not attempt to separate the register.
- (3) During transit, exercise care not to give impact shocks to the register.

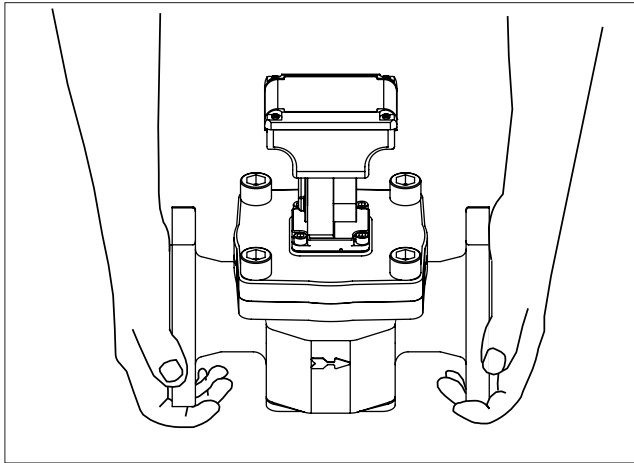

〈Hold like this.〉

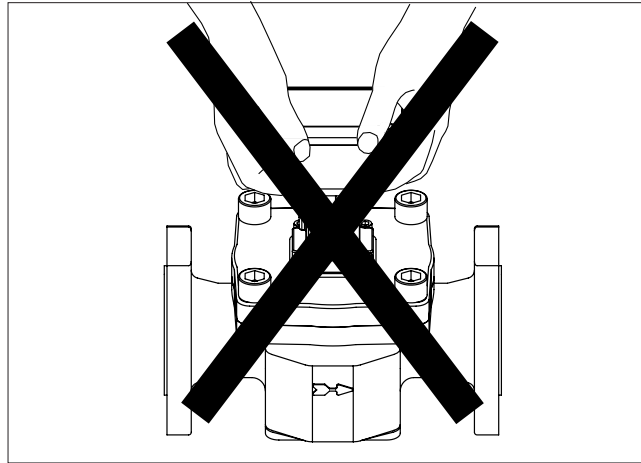

〈Don't hold like this.〉

1.3 Storage Precautions

If the instrument is to be stored over an extended period of time before installation, it could be involved in unexpected happenings. So if an extended period of storage is anticipated, the following precautions should be taken:

- (1) The instrument should be stored in the style packaged in our factory if circumstances permit.
- (2) Select a storage location that meets the following requirements:
 - * where it is free from rain and water.
 - * where vibration and impact shocks are least encountered.
 - * where temperature and humidity in the storage location are as near to the room temperature and humidity (25°C and 65% or so).
- (3) If you store the instrument which has been placed in service for any length of time, it should be purged with clean air or N₂ gas, etc. to keep the metered material from adhering to the flowmeter couplings, pipeline, housing, etc.
- (4) Use caution to keep the register away from thinner, alcohol or other organic solvents.



CAUTION

Do not attempt to disassemble the register and modify in any way.

(We cannot guarantee performance of modified Flowpet.)

1.4 Installation Location Precautions

- (1) In this register, a magnetic sensor is used to pick up magnetic fields of signaling magnets embedded in the rotor. For this reason, the instrument should be installed sufficiently away from sources generating magnetic field. If a magnetic valve 10 watts or so is used, separate it at least 10 centimeters from the flowmeter (depending on operating conditions).
- (2) **Application in cold regions**

To prevent the meter from freezing, install it indoors (in the boiler room, for example).

 - ① A vertical run is recommended for ease of pipeline drainage. Provide a drain plug. (See pipeline drawing on pages 18 and 19.)
 - ② Lagging is necessary. The register, strainer cover and drain plug should not be lagged, however. Take into consideration simple and ready separation of the meter from the piping assembly.
- (3) This register operates at temperatures between
– 10 to + 60°C. If exposure to elevated temperatures is expected by the direct rays of the sun, reflected heat, etc., protect the register against heat with a sunshade or heat shield to ensure its operation within the specified temperature range.
- (4) **This register is designed for indoor use: install in a location free from rainwater, oil, sunlight.**

If exposure to rainwater is unavoidable, provide an appropriate rain guard or sunshade.

2. OPERATING CONDITIONS

To derive the high accuracy and long life from this meter, it is necessary that the meter be used within the specified conditions in flowrate, pressure, temperature and viscosity. These operating conditions are stated on the nameplate of flowmeter's register and in the general specifications in Section 12 of this instruction manual. Familiarize yourself thoroughly with these instructions before installation and operation.



CAUTION

Under the Measurement Law, this instrument is not serviceable for certifying and authenticating legal transactions.

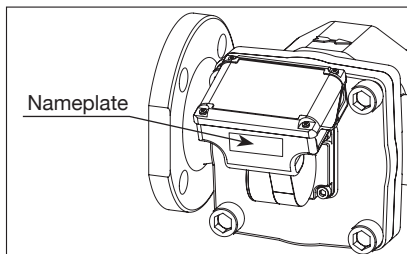

IMPORTANT: Read this instruction manual thoroughly before you start working on piping and initiate operation. See Section 4 for piping instructions and Section 7 for operating instructions.

3. GENERAL DESCRIPTION

The FLOWPET-5G is an OVAL flowmeter primarily intended for use in boiler feed water and fuel oil metering applications. Field proven accuracy and long life along with the best price/performance and ease of use make this industrial meter ideal as a dedicated tool for heat control.

3.1 Features

1. Available in two product families - for water service and fuel oil service.
2. Newly designed electronic register shows total flow and instantaneous flow on a digital LCD at the touch of a mode select button. The display angle can be adjusted for better visibility (Adjustable range: 75 degrees upward, 75 degrees downward).
3. The electronic register equipped models have an internal battery (good for 8 years); eliminates the need for an external power source. (Operation on external power source is recommended for external output equipped models.)
4. Improved display capabilities compared to the previous EG register.
 - LCD character height increased to 14mm from 10mm
 - Flow indicator allows user to intuitively check instantaneous flow rate
5. Factored pulse width is variable in 1ms steps with the back side buttons (adjustable 1 to 999ms).
6. Simulated outputs available. (external output equipped meter only) Pulse and analog output can be simulated at any flow rate for loop tests.
7. Reliable engineering unit pulses for total flow and fast pulse output are available.
8. Analog output available (2-wire, 4 to 20mA)

3.2 Product Code Explanation

In this instruction manual, the following combinations of products are described:

Item	Code (Digits)										Description		
	①	②	③	④	⑤	⑥	—	⑦	⑧	⑨		⑩	
Model	L	S										Dedicated Oval flowmeter (Standard model)	
Meter Size (Nominal dia.)												Water service	Oil service
	4	9										—	20mm (3/4")
	5	0										—	20mm (3/4")
	5	2										20mm (3/4")	25mm (1")
	5	3										25mm (1")	40mm (1·1/2")
	5	5										40mm (1·1/2")	40mm (1·1/2") Standard model only
5	6										50mm (2")	50mm (2") Standard model only	
Model Name					7							Flowpet	
Application					6	—						Oil service	
					7	—						Water service	
Register							5					Register(5G)	
Pulse Generator (※ 3)							0	0				No output capability (Local display only)	
							3	0				Factored pulse (pulse width 1ms), +Unfactored pulse (※ 1)	
							5	0				Factored pulse (pulse width 50ms), +Unfactored pulse (※ 1)	
							6	0				Factored pulse (pulse width 100ms), +Unfactored pulse (※ 1)	
							7	0				Factored pulse (pulse width 250ms), +Unfactored pulse (※ 1)	
							3	1				Factored pulse (pulse width 1ms), +Unfactored pulse (※ 1) +Analog output or Analog output only (※ 2)	
							5	1				Factored pulse (pulse width 50ms), +Unfactored pulse (※ 1) +Analog output	
							6	1				Factored pulse (pulse width 100ms), +Unfactored pulse (※ 1) +Analog output	
Temperature Range							7	1				Factored pulse (pulse width 250ms), +Unfactored pulse (※ 1) +Analog output	
											A	Oil service: Standard (0 to 120°C), JIS 10K RF	
											B	Oil service: Standard (0 to 120°C), ASME 150 RF	
											B	Water service: Standard (0 to 120°C), JIS 10K RF	
											C	Oil service: Standard (0 to 150°C), JIS 10K RF	
											D	Oil service: Standard (0 to 150°C), ASME 150 RF	

☞ Note: ※ 1 Unfactored pulse width is fixed at 2ms.

※ 2 If using analog output only, "Factored pulse (1ms) + Unfactored pulse (2ms) + Analog output" will be the specification.

Wire analog output lines (2 lines of the power wire) and leave the ends of pulse output (SIG.1 and SIG.2) cables open (not connected).

※ 3 Alarm output specification is available as an option.

3.3 Part Names

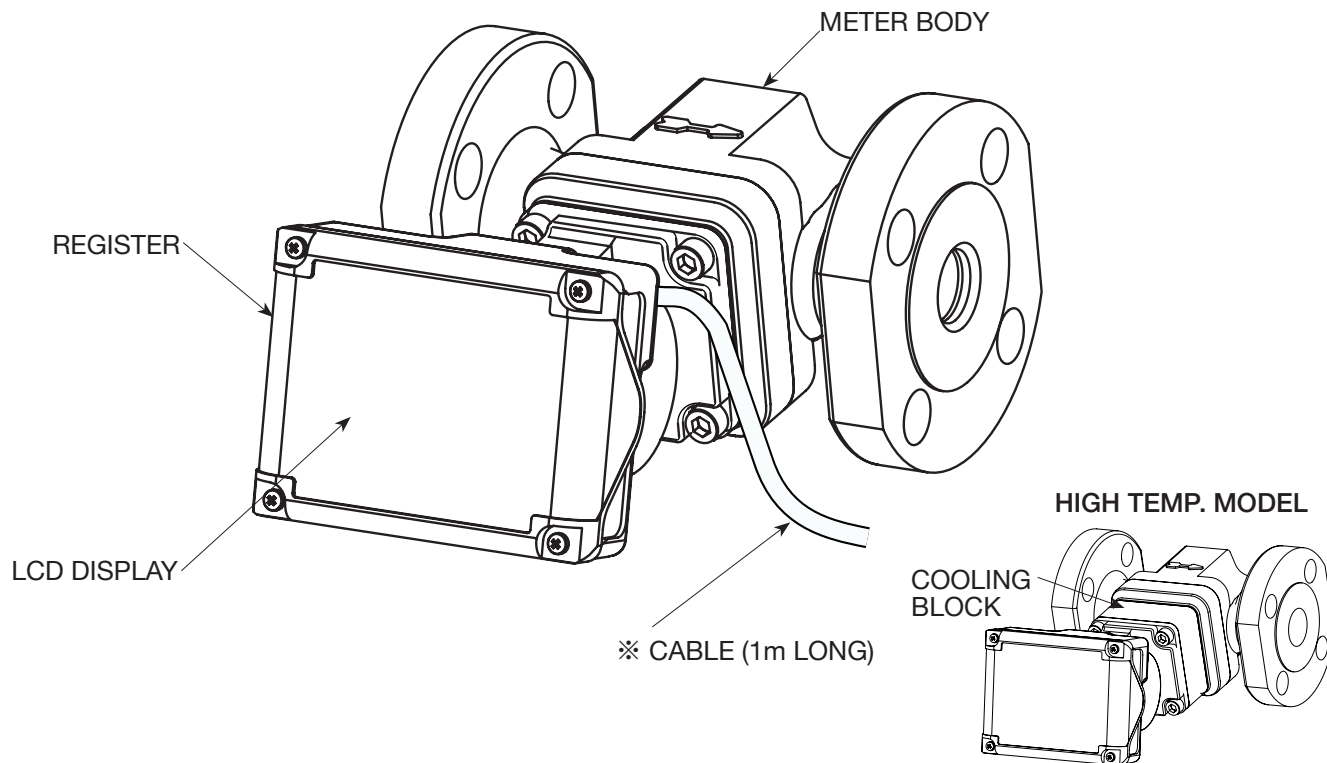

☞ (NOTE) Only external output equipped meters are furnished with the cable shown here with an asterisk ※ .

4. PIPING

4.1 Piping Precautions

- (1) Install the meter, exercising care to avoid pipe strains.
- (2) The meter should be installed downstream of the pump.
- (3) Provide a strainer upstream of the meter.
(NOTE) The strainer net used is 80 mesh for nominal size 20mm and 60 mesh for sizes 25 through 50mm.
- (4) Install the pump taking into consideration the pressure loss of the entire piping system. In case where the material is allowed to flow by means of a head instead of using a pump, a pressure (head) greater than the pressure loss of the piping system, flowmeter, strainer, etc. should be given.
- (5) To prevent inductive interferences, please be sure to connect to the earth ground for instrumentation one of the four mounting bolts securing the register with the flowmeter body, instead of the ground terminal.

● Pressure Losses of Flowpet

〈Water Service〉

Model	Pressure Loss kPa
LS5277	5 (1200 L/h)
LS5377	12 (3600 L/h)
LS5577	10 (7200 L/h)
LS5677	7 (12000 L/h)

〈Oil Service〉

Model	Pressure Loss kPa	
	Kerosene 1.2mPa·s	Heavy oil 19mPa·s
LS4976	32 (800 L/h)	47 (800 L/h)
LS5076	14 (1600 L/h)	40 (2000 L/h)
LS5276	13 (3000 L/h)	56 (3800 L/h)
LS5376	13 (5 m ³ /h)	30 (6.4 m ³ /h)
LS5576	25 (11 m ³ /h)	54 (14 m ³ /h)
LS5676	27 (20 m ³ /h)	55 (24 m ³ /h)

● Strainer Pressure Losses

Model	Pressure Loss kPa	
	Kerosene 1.2mPa*s	Heavy oil 19mPa*s
LS5278A	6 (300 L/h)	50 (3800 L/h)
LS5378A	7 (5 m ³ /h)	28 (6.4 m ³ /h)
LS5578A	23 (11 m ³ /h)	26 (14 m ³ /h)
LS5678A	25 (20 m ³ /h)	40 (24 m ³ /h)

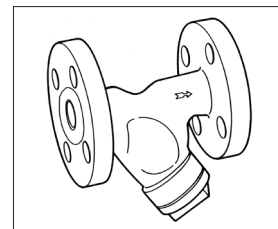

Strainer

- (6) Align the flow direction with the arrow mark on the meter body.
- (7) The pulse generator of this meter makes use of the changes in magnetic flux. To minimize influence of external magnetic fields, select an installation location sufficiently away from powerful magnets and conductors creating strong magnetic fields.
- (8) If electric heating is desired, consult factory.
- (9) When you conduct a gastight test on the existing piping assembly, careful valve operations sequence is required to safeguard the rotors against damage due to violent rotor spinning by rushing air currents. Adhere to the instructions on operation sequence described on page 32.

CAUTION: This model is not provided with subtract counter function. In applications where ripples (to-and-fro motion of the fluid under ripple pressure) or reverse flows exist in the pipeline, the total counter reading may not be consistent because it adds up flows irrespective of the flow direction.

4.2 Flushing the Piping Assembly

Be sure to remove the meter from the piping assembly and install a short pipe section in place of the meter. Flushing the piping assembly with the meter in place will result in serious, costly damage to the meter's measuring chamber.

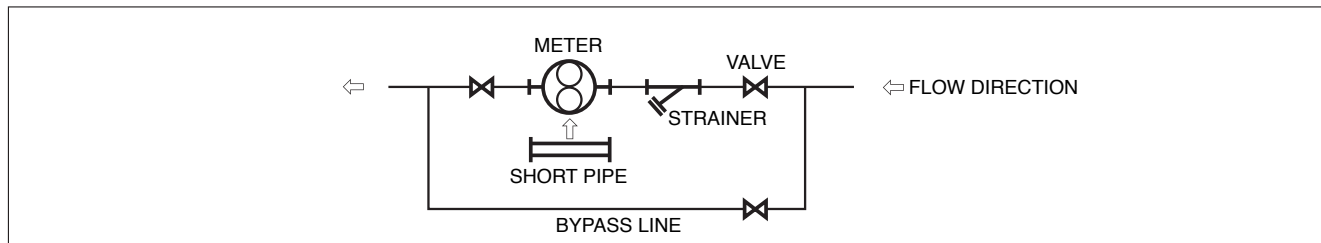

4.3 Lagging Work Precautions

For applications where the meter is to be placed in service in cold regions or where solidifying materials (e.g. Heavy oil) are to be metered, lagging work for the flowmeter and strainer is required.

- (1) Be sure to inspect for liquid leaks before covering with lagging.
- (2) Take into consideration simple and readily disassembly and inspection for the lagging of the meter.
- (3) Strainer should be lagged for quick top cover removal. Strainer net should be cleaned on a regular basis.
- (4) **Register and pulse generator must not be lagged.** If they are lagged, temperature will rise to an excessive level and result in costly damage (see figure on the right).
- (5) Heat insulation should not cover up the front cover register seat.
- (6) In applying heat insulation, take into account the ease of removal and disassembly.

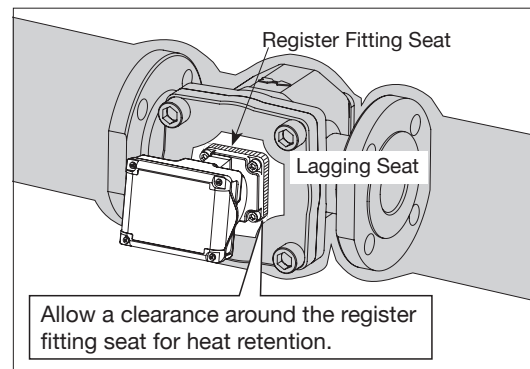

4.4 Examples of Installation

➡ NOTE: Make pipe connections observing the instructions under the topic “Piping Precautions” on Section 4.1.

● Horizontal Line.....standard piping

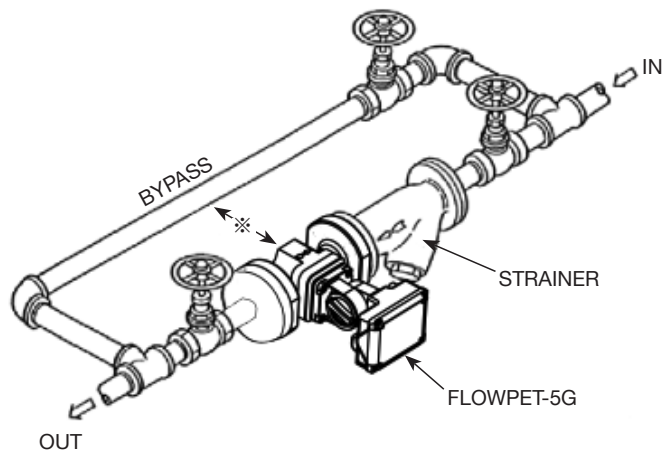

Marked ※ is the space required for disassembly and inspection.
Secure at least 600mm.

● Vertical Line

Install in the bypass side to prevent scales falling from top of the piping assembly.

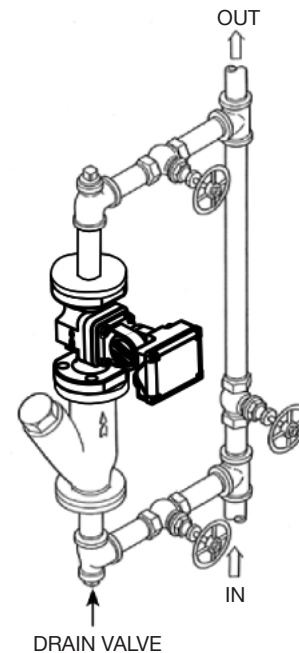

● Example of Incorrect Piping

- ⦿ Do not install the meter in a position like this.
(Installation is correct if the measuring chamber is on a level plane.)

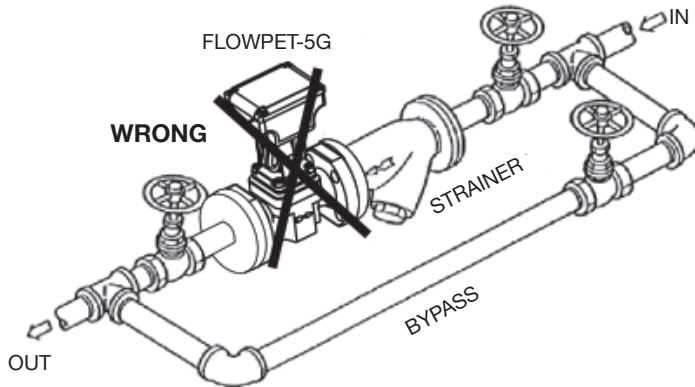

● How to prevent inductive interferences

Connect to the earth ground by using one of the mounting bolts

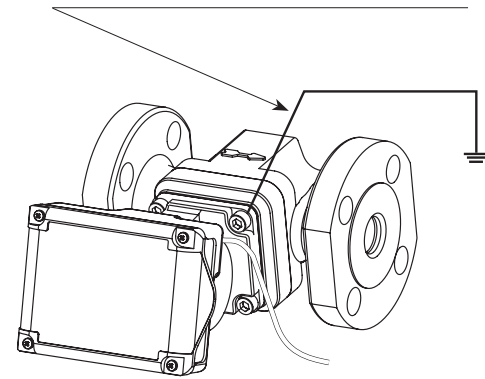

➡ **(Note)** To change flow directions, register face directions, see Section 4.5 (2).

If the flowmeter is equipped with external output capability, make electrical connections according to the wiring instructions in Section 5.

4.5 How to Change the Flow Directions and Display Orientations

(1) How to change the flow directions

The Flowpet is assembled to accept the flow from right to left. Flow directions can simply and readily be changed in the following manner:

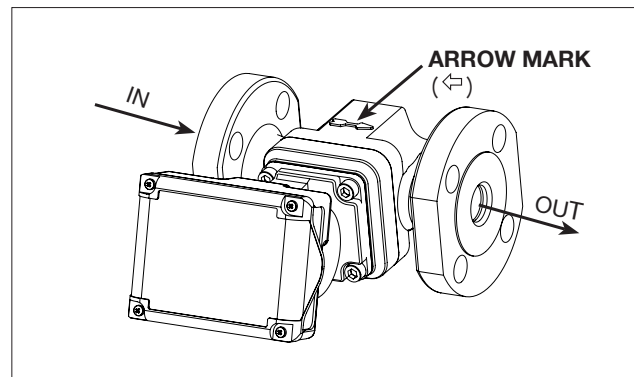
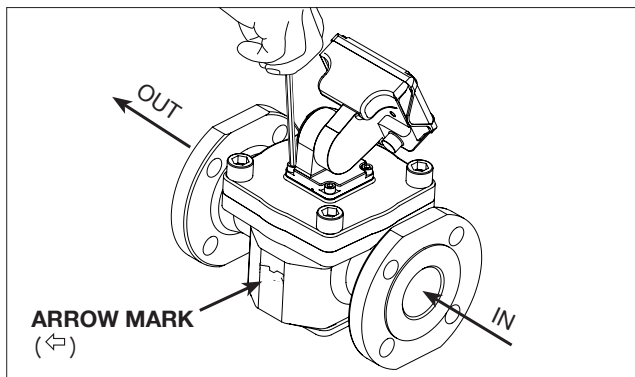

- ① Remove the meter from the pipeline and separate the register from the meter body. Align the arrow mark indicating the flow direction with the flow direction. In case of changing the flow direction from R-to-L to L-to-R, turn the meter body as shown in the sketch and reinstall in the pipeline.
- ② Align the physical orientation of the register correctly as shown and retighten the bolts. The same applies to changing the directions from L-to-R to top-to-bottom or bottom-to-top.

(2) How to change the register orientation

The register display can be easily adjusted by click stop in 15 deg. increment to a desired direction for maximum viewability. The adjustable range is 150 deg. upward or downward. See the sketches below.

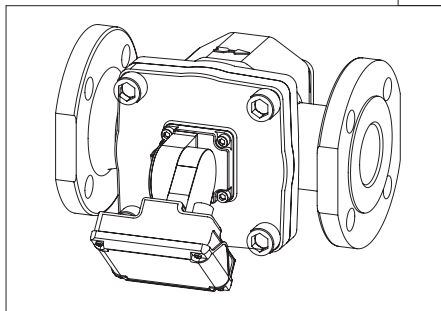
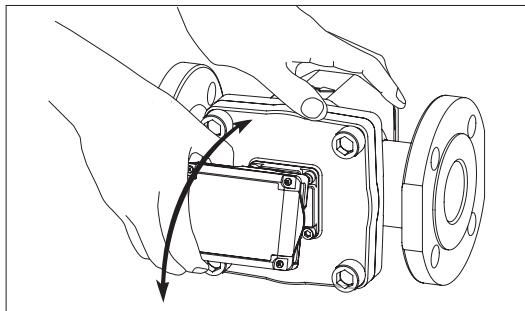

〈Tilted Downward (or Upward)〉

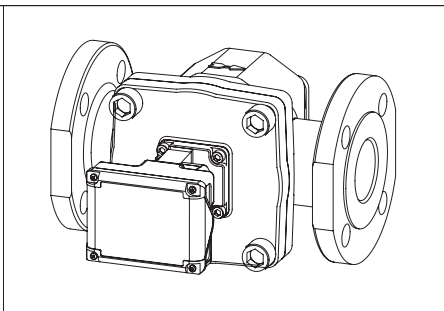

〈Facing Forward (Horizontal)〉

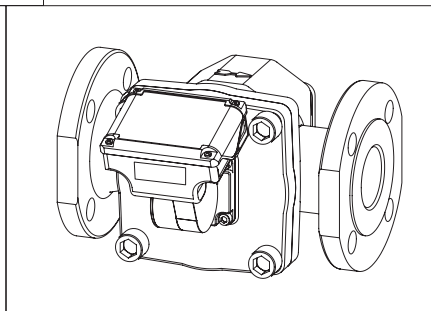

〈Facing Upward (or Downward)〉

5. WIRING

In case of external output capability equipped models LS□□77-571D, make electrical connections as follows. Also refer to the instruction manual for the receiving instrument (topic under “Wiring Instructions”) to be used.

5.1 Field wiring

(1) This flowmeter is furnished with 1 meter long cable (vinyl-sheathed, 4-conductor, individual elements AWG24). To extend the cable, make sure to use shielded cable (CVVS: 1.25 to 2.0mm²) and extend the shield as well. Leave the extended cable open at its end (no contact).

(2) Transmission length

With transmission cables (CVVS: 1.25 to 2.0mm²), the maximum transmission length is one kilometer. If using both analog output and pulse output, the transmission distance is 100m max.

➡ NOTE: If transmission length exceeds one kilometer, consult factory.

(3) Prevention of inductive interference

Route the field wiring sufficiently away from existing power cables or power circuits, if any, to minimize possible stray current pickup.



CAUTION

Make sure of the validity of flowmeter (pulse generator) and receiving instrument combination by referring to their model number, serial number, etc. before you make electrical connections.

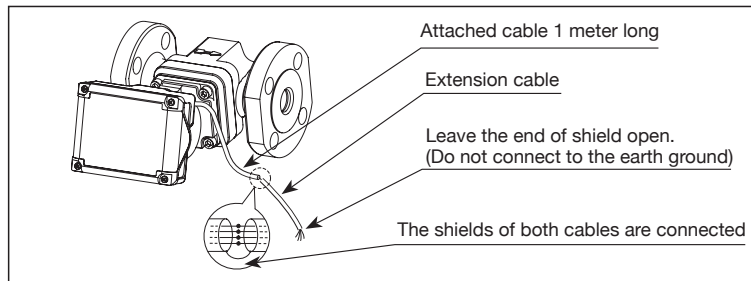

5.2 Furnished Leads from the Meter

In case of an output capability equipped meter, a shielded cable 1 meter long is furnished. Make electrical connections by referring to the wiring nameplate attached to the register.

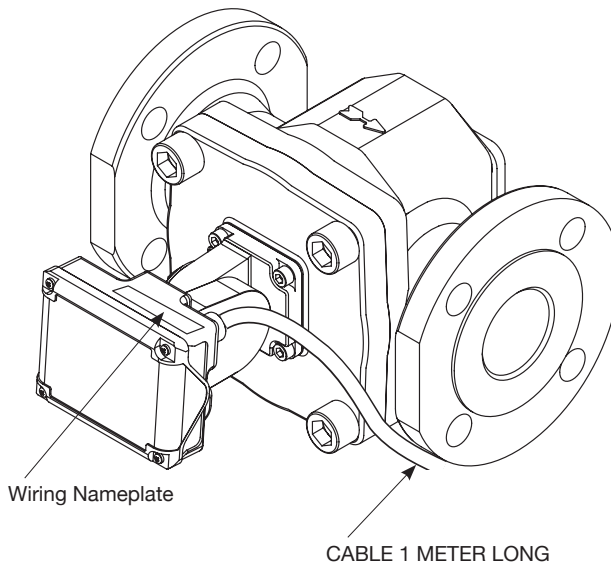

<Wiring Nameplate>

● Pulse output type

BROWN	SUP.	+12 to 50VDC
GREEN	COM.	0V
GREY	SIG.1	Factored pulse
WHITE	SIG.2	Unfactored pulse

● Pulse output + Analog output type

BROWN	SUP.	Analog output
GREEN	COM.	
GREY	SIG.1	Factored pulse
WHITE	SIG.2	Unfactored pulse

- ➡ (NOTE) 1. BROWN is for an external power source to the register.
2. Stripping the outer insulation from the shielded cable installed exposes a yellow wire, which must not be used.

● ABOUT EXTERNAL POWER SOURCE

IMPORTANT

- (1) The meter with external output capability can operate solely on the built-in battery. However, by supplying external power to leads **BROWN** and **GREEN**, it can work without consuming the battery. Also, even when the meter is operating on external power, do not remove the battery. (In case external power is interrupted for some reason, the operation is automatically switched to the battery drive.)
- (2) The shielded cable (1 meter long) attached to the instrument with external output capability is connected to the flowmeter body within the register. Accordingly, leave the shield of the cable open on the part of the receiving instrument. (Do not connect the shield to the earth ground terminal, 0V line of the power source, etc.)
- (3) An external power source is necessary for using analog output.

5.3 Hook-up Diagrams

(1) Flowpet-5G Output Circuitry

● Pulse output type

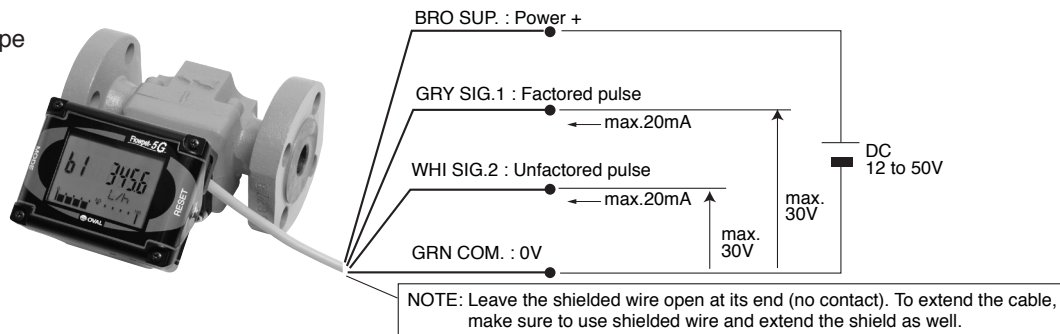

● Pulse output + Analog output type

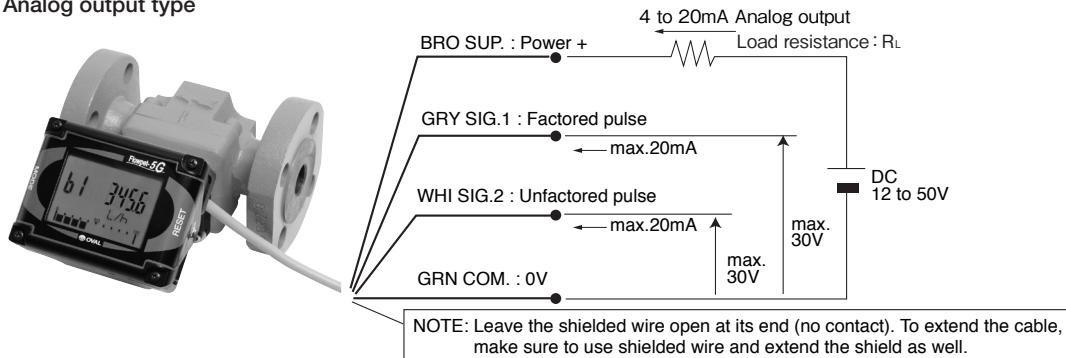

(2) About load resistance of analog output specification

In the analog 2-wire transmission system, power source cable is also used for signal wiring. Load resistance of analog output must be installed on the + side of the power. In addition, make sure that load resistance of the meter and leads are within the operating range shown in the right figure.

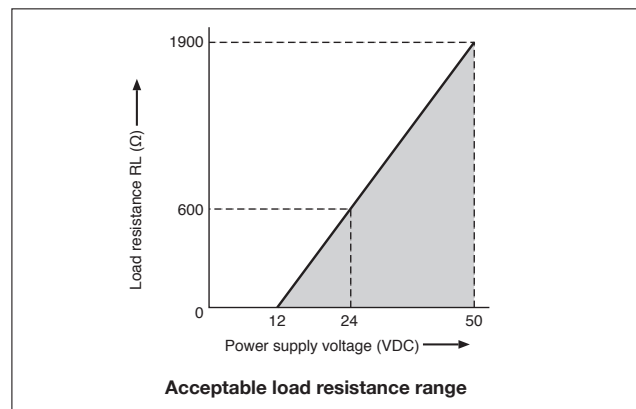

<Reference> When converting open drain pulse (equivalent of open collector) into voltage pulse:

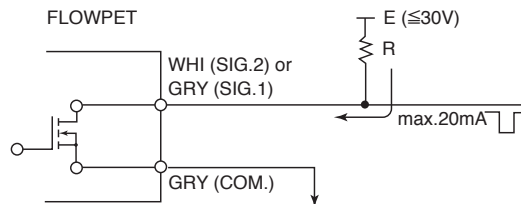

➡ (NOTE) Select the value of load resistance R depending on E so that current flowing through MOSFET becomes 20mA or less.



CAUTION

1. Both factored pulse output and unfactored pulse output are of open drain output (equivalent of open collector). Install the load to keep 30VDC max, and 20mA.
2. Operating out of the rating or wiring with wrong polarity may cause damage.

6 DISPLAY AND CONTROLS

6.1 Display and Operation Buttons

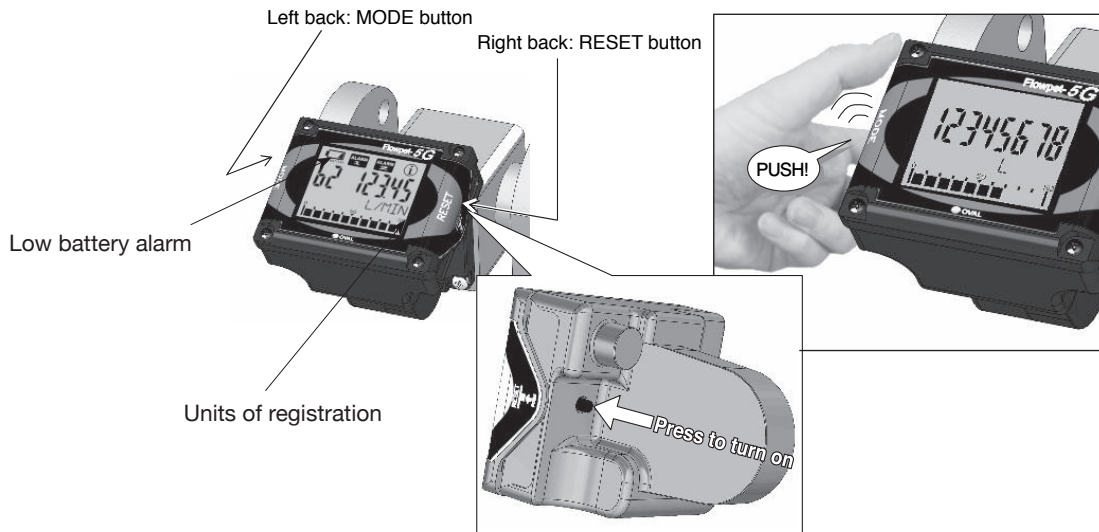

➡ (NOTE) About the Display Units

The units of registration can be changed.

L(std.), kL, m³, g, kg, t, gal, ft³, lb, /h, /min, (normal), none

Any change made to the display unit alone does not affect the process of flowrate calculation.

6.2 Display Capabilities and Operation

(1) Register

Because the register face can be changed to a desired direction in increments of 15 deg., there is virtually no limitation in choosing meter installation location. As to how to change the physical orientation, see Section 5. Built around a microprocessor, The register is capable of various display and pulse and analog signal output. These functions operate on an internal lithium battery which eliminates the need for any external power source. (External output is also available on an external power.)

(2) LCD display

The 8-digit LCD digitally displays accumulated total, instantaneous flow rate (hourly and per-minute), and resettable total count, flow rate unit, instantaneous flow rate indicator, and low battery alarm.

(3) External output signal <MODEL LS□□7⁶7⁵³—⁵⁵0⁵⁶⁵⁷1^A_B^C_D>

Generates pulse and analog signals for remote flow measurement. See Section 5 for field wiring.

Factored pulse (SIG1) → for flow totalization

Unfactored pulse (SIG2) → for flowrate indication and recording

Analog output → for instantaneous flow rate monitoring

(4) Reset pushbutton

Only in the reset total “C mode”, total count is resettable.

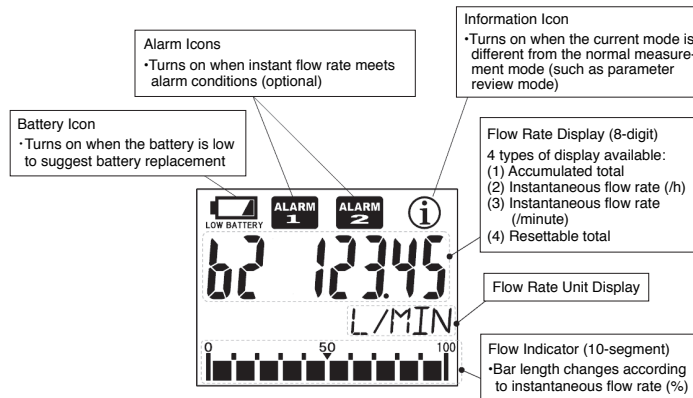

(5) Mode selector pushbutton

Each time the “MODE” pushbutton is depressed, accumulated total, instantaneous flowrate (hourly and per-minute) and resettable total are displayed sequentially.

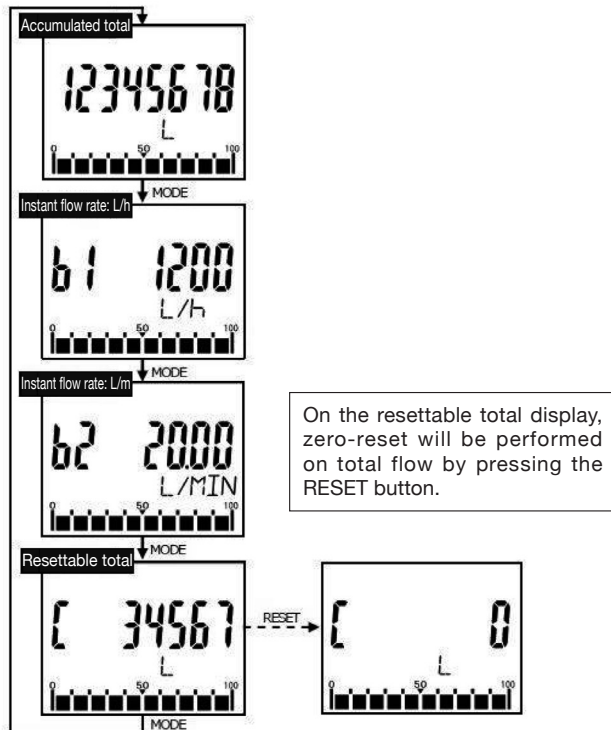

➡ (NOTE)

1. Depressing the MODE button to obtain an instantaneous flow rate while the meter is in operation, the internal counter keeps counting the flow for accumulated total.
2. At very small flow rate below meter's minimum flow rate, the instantaneous flow rate display remains “0”. However, totalizing continues to count.
3. Instantaneous flow rate reading may vary depending on operating conditions and other contributing factors.
4. The display screen scrolls when the MODE button is released. Holding the MODE button down for more than 5 seconds will make a transition to parameter review mode.
5. In this instruction manual, “turned ON” refers to the state where a finger holds the button depressed.

(6) About the Displayed Messages during Operation

① Ordinary operation

When MODE button is pressed, 8 bars appear.

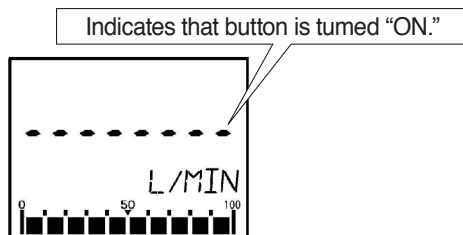

⇒ Immediately turning "OFF" scrolls the window to the next one.

➡ (NOTE)

In the mode validating "RESET" button operation (resettable total mode, etc.), the same messages as above also appear in response to "RESET" button depression. (In this mode, however, there is no distinction between normal depression and prolonged depression.)

(7) Flow Indicator Display

Using full scale flow rate setting (parameter: AF) as 100%, instantaneous flow rate is indicated in 10 segments.

(The maximum flow rate of standard specification is set at the time of shipment,)

② Prolonged operation

Held depressed ON without turning "OFF" immediately.
⇒ Bars begin to disappear from the leftmost one.
Indicates a countdown before "prolonged depression" processing takes place.

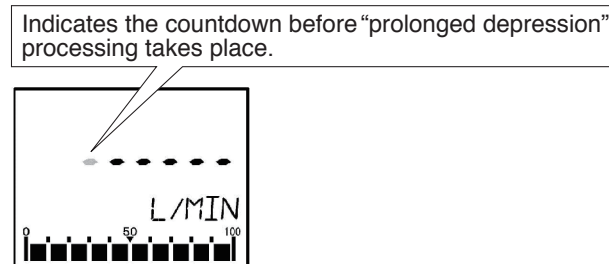

⇒ By holding MODE button down until the last dash disappears, "prolonged operation" process (※) takes place. (Releasing MODE button before the last dash disappears results in the same behavior as in ① to take place.)

※ prolonged operation: Operation required for Normal mode ⇔ Parameter review mode selection, finalizing the parameter setting, etc.

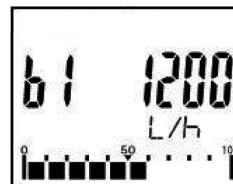

7. OPERATION

7.1 Operation

- (1) Read the information given on the nameplate before commencing operation and make sure to see the operating conditions conform to the specifications. Also make certain that meter installation, pipeline connections and electrical wiring have been made correctly.
- (2) Carefully follow the valve operations sequence given below. On a new installation, care should be exercised to prevent the rotors from spinning violently by compressed air. (See next page.)
 - ① Close the valve A upstream of and the valve B downstream of the meter.
 - ② Slowly open the valve C on the bypass line to allow the liquid to run through the bypass line, washing away weld chips, scales or other foreign matter inside the pipeline.
On a newly installed piping assembly, extra care should be used. See Section 4.2 for flushing instructions.
 - ③ Slightly open the valves A and B. Slightly close the valve C if necessary. Make sure to see the counter of the register slightly moves in response at this time.



- CAUTION**
- 1. In case where the meter is used with heavy oil exceeding 80°C in temperature, maintain this condition at least for 10 minutes to obtain uniform temperature distribution in the measuring chamber.**
 - 2. If you plan to use the water service FLOWPET for boiler feed water, keep the concentration of antiscaling/corrosion inhibitor and deoxidizing agent according to their instruction manuals. Exceeding their prescribed concentration may lead to corrosion of the meter and other problems.**

- ④ After a warmup period, slowly close the valve C and progressively open the valves A and B until the rated flow is reached.
- ⑤ Flowrate is adjustable with the valve B downstream of the meter. Use the meter within the flow range specified.

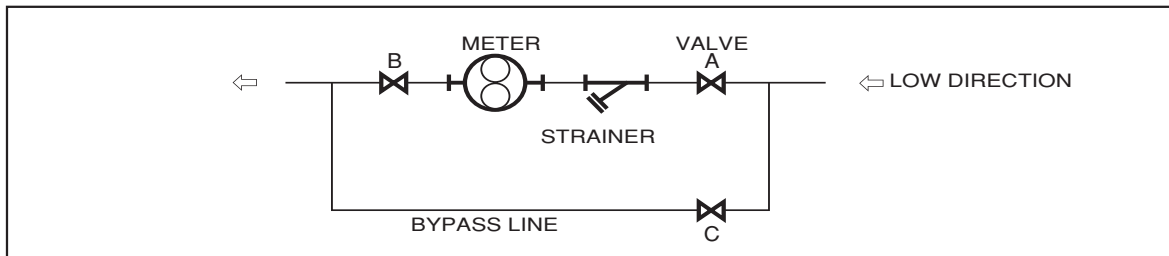

- (3) In applications where materials that tend to solidify are to be metered, lagging work is necessary. See Section 4.3 for lagging work.
- (4) The strainer net should be inspected and cleaned on a regular basis. On a newly installed piping assembly in particular, daily inspection of the net for condition is necessary, stretching the inspection intervals progressively to once in two or three days down according to the result of inspection.
- (5) **In case of freezing risk while pausing the operation or intending shutdown for a long period of time:** Remove the drain plug of piping assembly and let the water in the meter and piping assembly out. Water remaining in the pockets in the meter may not be drained completely. So disassembling the meter for complete drainage is recommended. (See Section 9 for disassembly procedure.)



Valve operation shown in the sketch will cause violent spinning of meter rotors which may ruin your meter. Use both hands for careful valve operation.

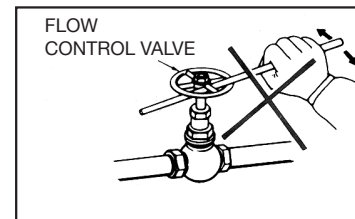

7.2 About Register's Life

Due to the life expectancy of electronic components, such as LCD device, and nonvolatile memory, the electronics in the register requires replacement as an assembly every 10 years approx. The life of electronics may possibly be more or less reduced, depending on the given environment in which the register is placed. If the environment comes under any of the following conditions, we suggest you to replace the register assembly in five or six years:

- ⊙ High temperature environment.
- ⊙ Adverse environment with widely varying temperature.

7.3 Battery Life

(1) The lithium battery incorporated in the register is good for approximately eight years (it may be reduced more or less depending on the operating and environmental conditions). Operation on external power source is recommended for the pulse output models. (Supplying external power source will save the battery.)

(2) When the battery has run down, the low alarm icon “  ” begins to flicker on the display. This blinking icon tells you to replace the battery unit within a week. (See section 11.1 (4) for battery replacement.)

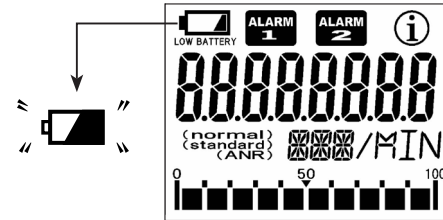

(3) Storage life of the battery is 10 years approx after shipment.

Normally, even in an application where the register is powered by an external source and the battery appears virtually free from any current drain, the storage life requires replacement in ten years approx. (Taking the abovementioned life expectancy of the register, replacing the entire register assembly will thus be required.) The battery may possibly have even a shorter storage life under any of the following environments, requiring early replacement:

- ⊙ High temperature environment
- ⊙ High temperature fluid measurement
- ⊙ Cold region

8. TROUBLESHOOTING

Symptom	Possible Cause	Remedy
1. Fluid will not flow.	1. Pipes are connected without removing protective covers over the inlet and outlet of flanges of the meter.	1. Remove the meter and remove the covers.
	2. Oval rotors are jammed with scales and fail to rotate, blocking the fluid flow.	2. Separate the register, disassemble and clean the meter body.
	3. Pump pressure or head pressure is low.	3. Taking pressure loss of the entire piping system into consideration, choose a pump that best suits your application. (See Section 4. PIPING)
2. LCD counter (b1, b2 modes) fails to count.	1. Flowrate is low.	1. Carefully open the valve.
	2. Fluid not flowing.	2. Refer to Symptom 1.
3. Steady-ON "E" on the LCD.	1. Battery voltage has dropped.	1. Replace the flowmeter, the counter unit or battery unit within a week.
4. Liquid leaks.	1. Sealed improperly.	1. Retighten pipe connections. 2. Replace the O-ring on meter body cover.
5. Liquid flows but the register fails to count	1. Rotors are installed backwards.	1. Disassemble the meter body and reinstall the rotors so that the magnets on the rotor will face the meter body cover.
6. Counts while valves remain closed (without fluid flow).	1. Liquid leaks. Or air pockets between the valve and meter: rotors oscillate relative to ripple pressures of the pump.	1. Provide an air bleed. 2. Provide a check valve and accumulator.
7. Accumulated total high.	1. Rotors in rocking motion in response to a pulsating flow.	1. Add a check valve and accumulator.
	2. Influenced by external magnetic fields (Meter sensor senses external magnetic fields created by a motor, generator, etc.).	2. Remove external magnetic fields.
	3. Air entrapment.	3. Provide an air vent.
8. Accumulated total low.	1. Influenced by external magnetic fields.	1. Remove external magnetic fields.

● NOTE:

When troubles is found other than any of those shown above, seek our service. In this case, please supply the product name, model number, symptoms or other information that will help distinguish the trouble.

■ About Error messages

In cases of improper situations, the 5G register displays error messages on the LCD as follows:

Display	Name	Description	Remedy
PA. Err.	Parameter setup error	Rewriting a parameter is attempted although the parameter is write-protected. (In standard model, parameter write-protect function is turned OFF; it will not be shown.)	Setting No.1 of SW3 of the display board OFF cancels this condition (rewriting parameters is enabled).
PA. Err. 1	Parameter error 1	Parameter backup data has been lost.	Parameters must be reset after initializing the CPU. (Please contact the nearest sales office)
PA. Err. 2	Parameter error 2	Display modes, accumulated total flow, or resettable total flow variable has been lost.	Pressing the MODE button restores the normal measurement mode, but variables of accumulated total flow and resettable total will be reset.
PA. Err. 3	Parameter error 3	Parameter data for factory reset has been lost.	Pressing the MODE button restores the normal measurement mode, but factory reset function will remain disabled.
PA. Err. Pu	Pulse weight error	Relative to meter factor F and conversion factor H, pulse weight "Pu" setting is too small.	Adjust settings so that F, H, and Pu satisfy the following relations: $F \times H / 2 \leq Pu \leq F \times H \times 10000$
Out. Err	Pulse output error	For one of the following two reasons, pulse OFF width of factored pulse output falls short of 1msec. ① Flow rate is too high ② Factored pulse width setting is too large	In case ① : Reduce the flow rate. In case ② : Adjust factored pulse width Pon to an appropriate value according to the flowmeter specification.
FS. Err	Full scale error	For one of the following two reasons, measured flow rate is more than 1.2 times the full scale setting. ① Flow rate is too high ② Full scale setting is too small	In case ① : Reduce the flow rate. In case ② : Adjust full scale setting to an appropriate value according to the flowmeter specification.
(Battery icon blinking) 	Low battery life	Circuit voltage is decreasing.	Replace the battery. (If replacing the battery does not clear this condition, internal failure is suspected.)

Internal switches and test electrodes

With the test electrodes (TP0 through TP4) inside the register, signal waveshape and internal voltage can be monitored.

Internal PCB (FB board)

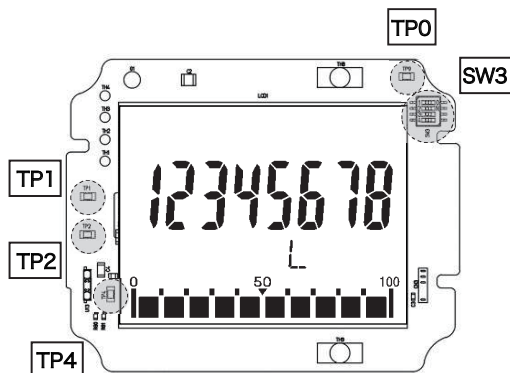

Label	Name	Description
TP0 (0V)	Test electrode for monitoring reference potential (0V)	Reference potential (0V) for monitoring waveshape and circuit voltage
TP1 (FWD)	Test electrode to monitor amplified signal waveshape	For monitoring amplified magnetic sensor signal waveshape
TP2 (TRG)	Test electrode to monitor triggered signal waveshape	For monitoring triggered waveshape (rectangular wave) of signal at TP1
TP4 (4V)	Test electrode for internal voltage 4V	For testing internal circuit voltage (4V) * Output 4V while external power is supplied, output 0V when running by battery power.

- ➡ NOTE
1. Description and handling of the waveshape monitoring test electrodes TP1 and TP2 are the same as the previous EG register. (TP3 [waveshape past the doubler] is not equipped on 5G register, however.)
 2. SW3 is for factory setting and does not require further adjustment. All settings are placed in OFF at the time of shipment.

9. DISASSEMBLY AND INSPECTION

⊙ Although it depends on individual operating conditions, periodic disassembly and inspection every year is recommended.

〈Meter Body Disassembly and Inspection〉

● MODEL LS4976, LS5076

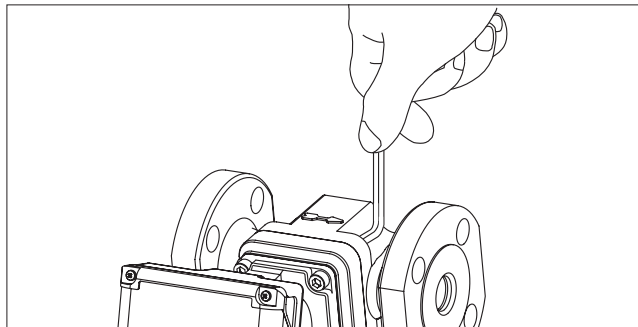

(1) Take off four hex bolts of the meter and separate the register from the meter body.

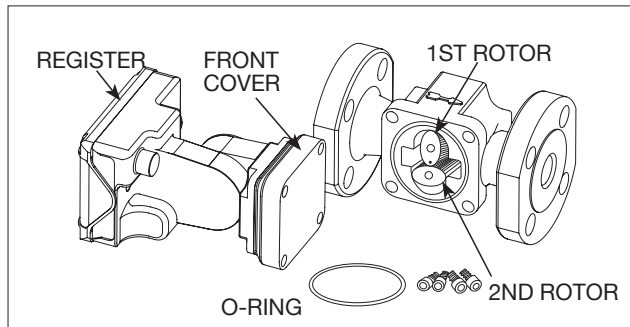

(2) Holding the register and front cover, separate horizontally. Inspect the measuring chamber and remove scales on individual parts. Exercise extra care not to drop the rotors or they will be damaged.

● **MODEL LS5276, LS5376, LS5576, LS5676, LS5277, LS5377, LS5577, LS5677**

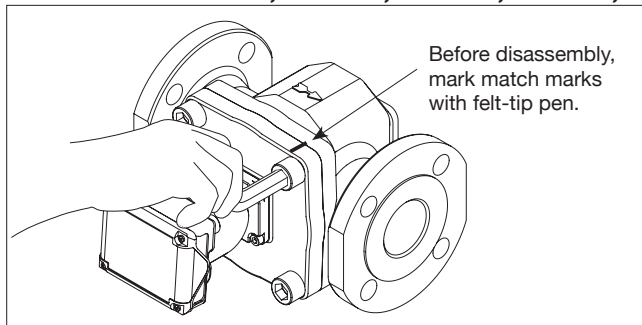

- (1) Take off four hex bolts of the meter and separate the register from the meter body.

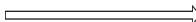
In case of LS55 □□ and LS56 □□ ,  threading two bolts into the jack screw holes provided (marked ※) in the front cover will facilitate removal.

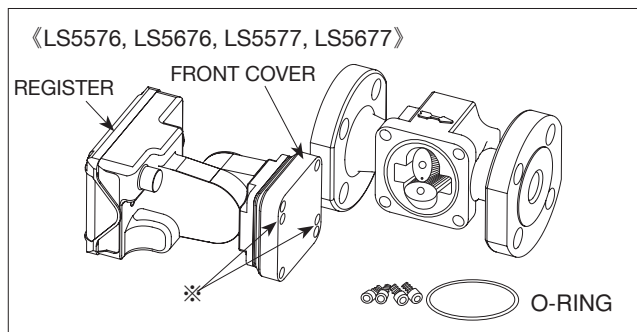
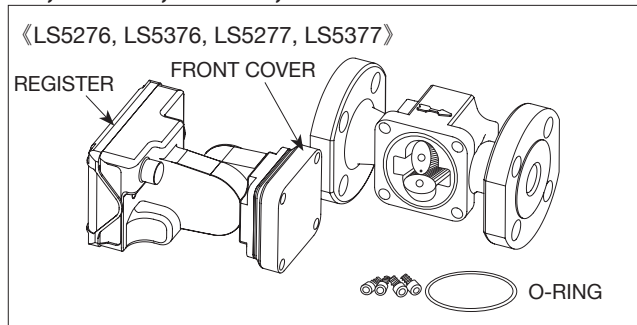

- (2) Holding the register and front cover, separate horizontally. Inspect the measuring chamber and remove scales on individual parts. Exercise extra care not to drop the rotors or they will be damaged.

⚠ — Precautions at Assembly —

Assembly is the reverse order of disassembly. Observe the following instructions:

- (1) Assemble the rotors as shown in the sketch. Hand rotate more than one complete rotation to make sure of freely rotor rotation before installation.
- (2) Although identifying the 1st rotor from the 2nd is not required except for LS4976, LS5076 magnet polarities differ. Be careful to avoid confusion with other products. When replacing rotors, replace them as a matched pair. Only in the LS4976, LS5076 the 1st rotor has magnets (two embedded). Installing the 1st and 2nd rotors the other way do not affect functions by any means. Install the rotors so that the magnets on the rotor will face the meter body cover.
- (3) Before installing O-rings, ensure that they are free from damage or other unusual condition and exercise care to avoid being caught in the front cover.
- (4) At assembly, use care to keep dust and grime out of the measuring chamber, which may cause failure, immovable rotors, or other faulty condition.
- (5) Do not attempt to spin the rotors at great speeds by directing an air gun, etc.

⚠ <CAUTION>

1. Score marks, scratches, high spots due to impressions, or other flaws should be reconditioned flat with oil stone or other tool.
2. If the areas which have been in contact with front cover jack screws are distorted outwardly, recondition it flat with oil stone.

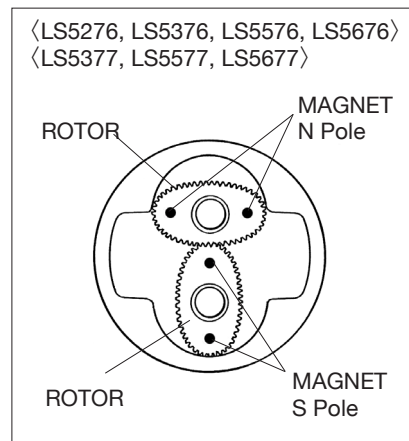
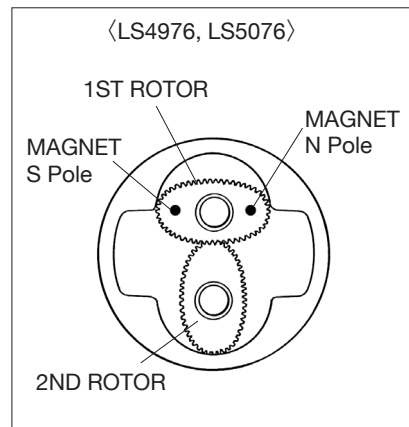

10. EXPLODED VIEW AND SERVICE PARTS LIST

(1) Exploded View

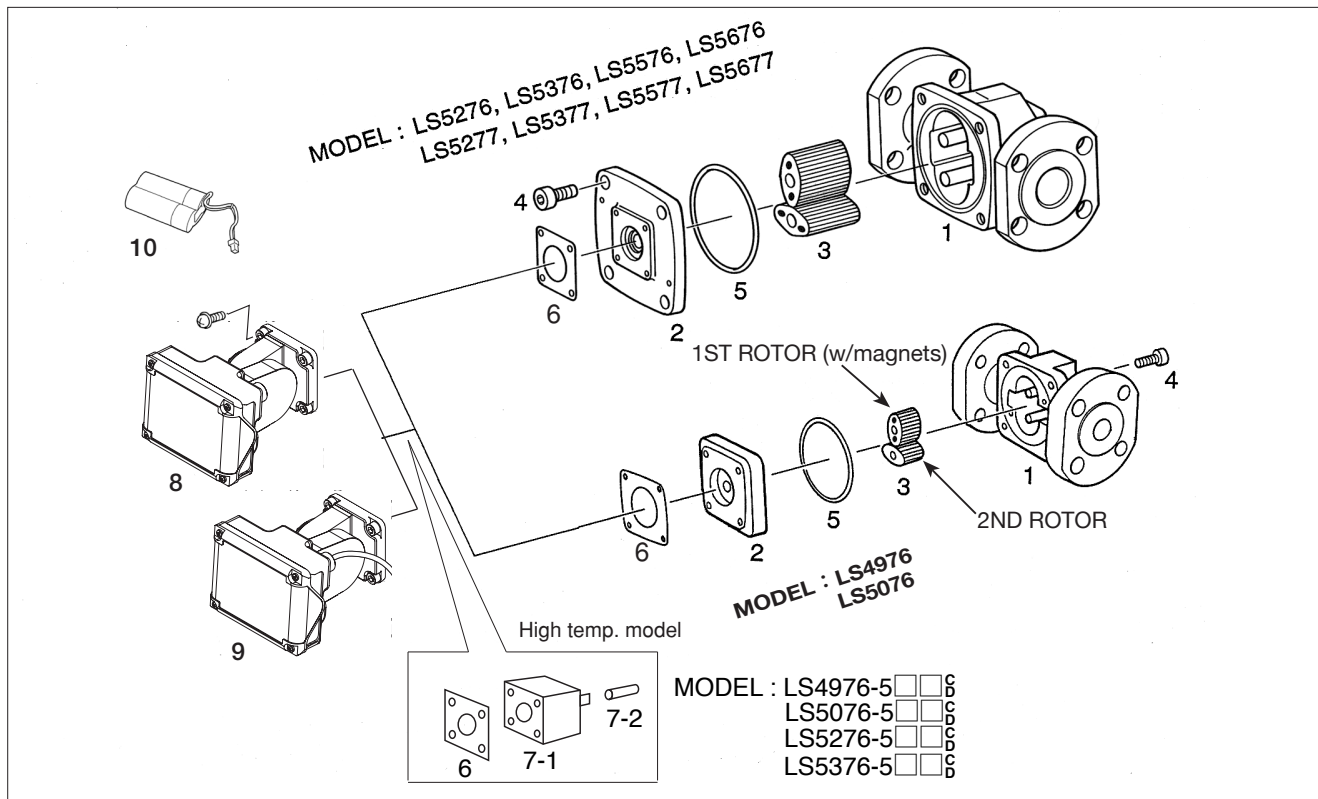

(2) Service Parts List

No.	Assembly Name	Part Name	Quantity	Remarks
1	Basic Unit	Basic Unit	1set	
		Rotor Shaft		
2	Front Cover	Front Cover	1	
3	Rotors	1st Rotor	1set	with magnet ※
		2nd Rotor		
4	Bolts	Hex Bolt, Front Cover	4	
5	O-Ring	O-Ring	1	
6	Gasket, Register		1	
7-1	Cooling Block		1	
7-2	Iron Slag		1	
8	Register		1set	with battery pack
9	Register with external output	Please inform digits ⑥ , ⑦ , and ⑧ (representing register and output specification) of the product code.	1set	with battery pack
10	Battery pack		1set	

➡ NOTE ※ : Only in LS4976, LS5076 magnets are embedded in the 1ST rotor.

● How to order Flowpet replacement parts

- (1) Specify by assembly name. When ordering replacement parts, specify the model number ○○○○○○ , instruction manual No., assembly name and the quantity desired.
- (2) When ordering the register, inform us the parameters indicated (shown in the sketch at right) along with the information (1) above.

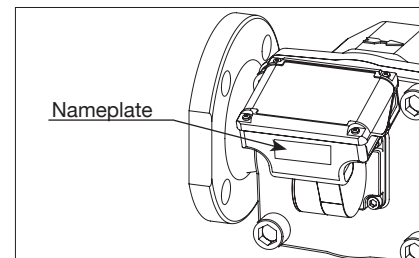

11. BATTERY REPLACEMENT AND PARAMETER SETTING PROCEDURE

11.1 Battery Replacement

- (1) The lithium battery incorporated in the register is good for approximately eight years. (The battery life may be reduced more or less depending on the environmental conditions and other factors.)
- (2) When the battery has run down, the low alarm icon “” begins to flicker on the display. This blinking icon tells you to replace the battery unit within a week.

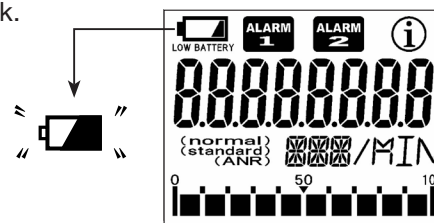

- (3) This battery is a dedicated battery pack with a connector. Other commercially available batteries cannot be used. Be sure to use the battery pack dedicated to this register.

(4) Battery pack replacement

① If using external power source, disconnect the power first. Take off the four cross recess screws holding the register housing. Remove the cover to access the internal PC board. Next, hold both sides of the LCD and lift the internal PC board. The battery pack is now accessible.

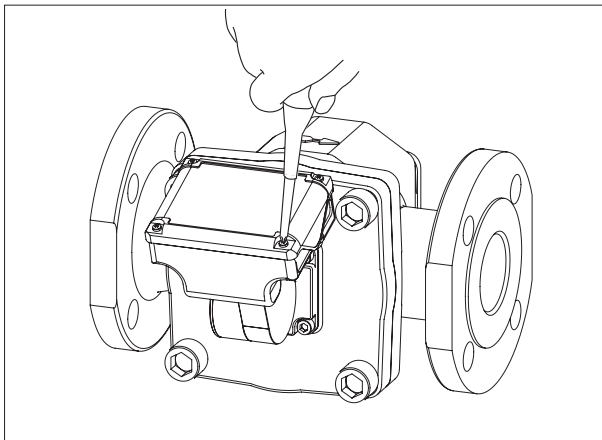

② Pull out the battery pack and uncouple the connector from the internal PC board by holding the lead wires close to the connector and pulling it vertically up.

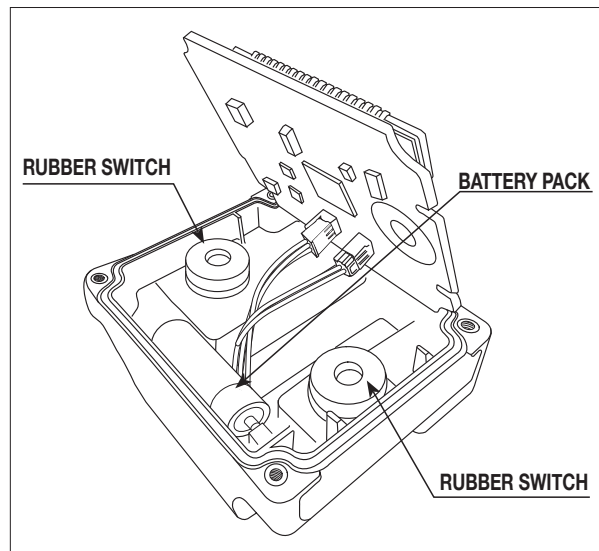

⇒ See next page



CAUTION

Over a long period of time, the rubber switches may adhere to the PC board. Use caution when lifting the PC board. If the rubber switches come off the housing, place the rubber switches back (at the dents on the sides of housing interior) then resume the procedure for battery replacement.

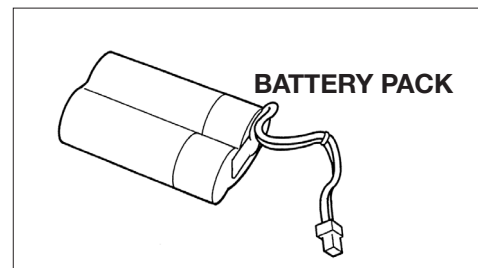
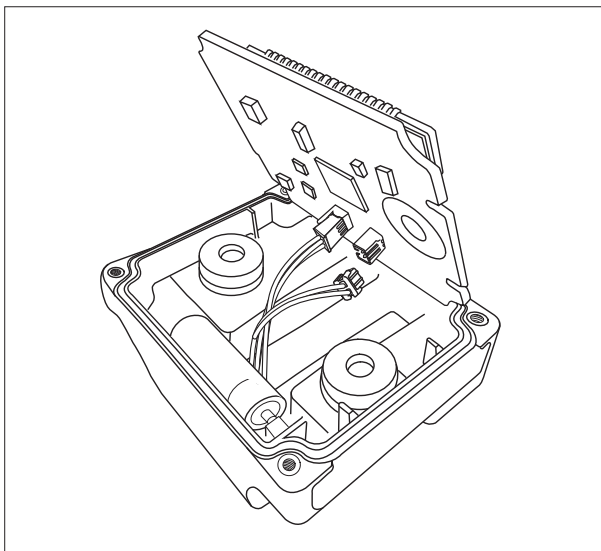

- **Replacement battery packs are available at your nearest sales office.**

- ③ Install a new battery pack in place: install it with its red wire lead on the “+” polarity side. Then carefully place the PC board back into its original position without jamming the lead wires between the housing and the PC board, and install the cover.
- ④ When installing register housing tighten four cross-recess screws to the specification below: (Allowable tightening torque: 0.4[N • m])

⚠ (CAUTION) When you separate the register housing, be extremely careful to keep moisture and dust out. Also, keep your fingers off the electronics.

11.2 Parameter Setting Procedure

If you want to rewrite some parameters of the register, such as the unit of accumulated total, it is necessary that the parameters stored in the CPU be rewritten. If such is the case, rewrite parameters by the following procedure.

(1) Parameter Setting

In cases where replacing the entire register assembly is required, or restoring the factory established parameter settings is desired, refer to the parameter list.

Unfactored pulse unit and factored pulse unit are stated in the nameplate (see below).

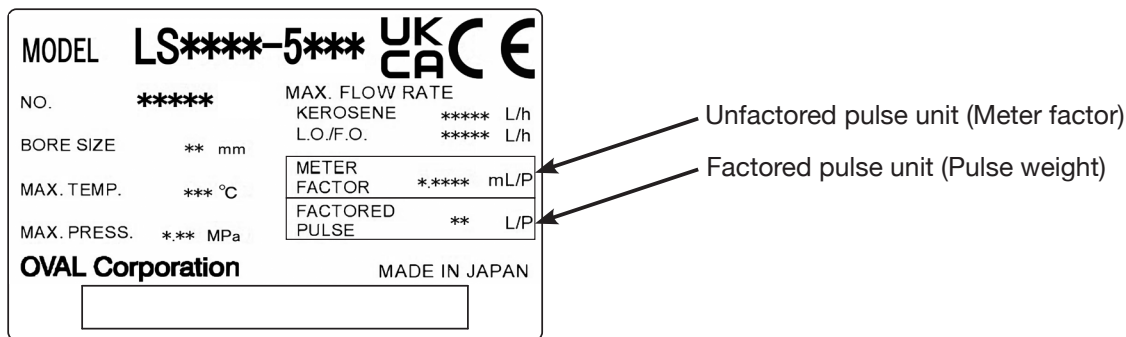

Nameplate

(2) Parameter List (1/2) (NOTE: Flow unit "L" written under "Description" in the following table refers to the standard setting.)

• Total flow related data (Title Display: totAL)

Symbol	Parameter	Description	Remarks
F	Meter factor	Meter factor of the flowmeter (Unit: L/Pulse)	Example: Given meter factor 9.918mL/P (= 9.918 × 10 ⁻³ [L/P]) → Set to "F9.9180 - 3" (L/P).
H	Conversion factor	Unit conversion factor (Unit:[Converted Unit/L])	To convert total flow and instant. flow rate units to units other than L. (Normally H1.0000E0 unless unit conversion takes place.) Example: at 1.5kg per 1L, to convert the flow rate to read in kg → Conversion factor is 1.5 [kg/L] (=1.5000 × 1000[kg/L]); Set to "H1.5000E0" [kg/L]. (Note 1)
Pu	Pulse weight	Pulse weight of factored pulse output (Unit:[L/P])	Example: To change factored pulse weight to 10L/P (=1.00 × 10 ⁻¹ [L/P]) → Set to "Pu 1.00E1" (L/P). (Note 2)
Pon	Pulse width	ON width of factored pulse (Unit:[msec])	Example: To obtain factored pulse width of 100ms → Set to "Pon 100" (ms). (Note 3)
Un	Indicated unit	Description of unit display on the bottom of the LCD	By changing Un, units that appear on LCD can be changed. (This is a change in indicated units; it does not affect flow calculation.) Setting items: mL, L, kL, m ³ , gal, ft ³ , g, kg, t, lb, none
SP	Total flow decimal point	Decimal point of accumulated total and resettable flow	Example: To show total flow to 0.01L (= two places below decimal point) → Set to "SP .2".
d.o1	Digital output assign. 1	Output spec. of SIG1 (Color: GRN)	Setting items: U,PLS: Unfactored pulse, PLS: Factored pulse, AL.1: Alarm 1, AL.2: Alarm 2, -: No assignment (Alarm capability is optional.)
d.o2	Digital output assign. 2	Output spec. of SIG2 (Color: WHI)	
d.o3	Digital output assign. 3	This product does not use this parameter.	

• Instantaneous flow related data (Title Display : rAtE)

Symbol	Parameter	Description	Remarks
AF	Full scale flow rate	Full scale flow rate for flow indicator and analog output (Unit: L/h)	Example: To set full scale flow rate of analog output to 1800L/h (= flow rate that is represented by 20mA) → Set to "AF 1800" (L/h) Note that the place of decimal point depends on bP.
AdAn	Damping	Time constant for instantaneous flow rate value (Unit: [sec])	In case ripple of instant. flow rate display and analog output is too great, setting larger value for AdAn will stable the indication. Example: To set time constant of instantaneous flow rate display and analog output at [5sec] → Set to "AdAn 5.0".
bP	Instant flow decimal point	Decimal point place of per-hour instantaneous flow rate: b1 measurement	Example: To show instantaneous flow rate to 0.1 L/h (= one place below decimal point) → Set to "bP .1". Per-minute instant. flow rate: b2 is bP+2 digits
At	Sampling time	Timeout duration in instantaneous flow rate measurement (Unit: [sec])	If no flow rate pulse arrives during At [sec], instantaneous flow rate is 0.
A	Sampling cycle number	Number of sampling cycles in instantaneous flow rate measurement	Instantaneous flow rate is determined by timing the incoming flow rate pulses for A times. If dispersion in instant. flow rate indicated is too great, choosing a greater A eases the problem.

➡ (NOTES) 1: In case of changing conversion factor (H), related parameters such as pulse weight (Pu) and indicated unit (Un) must also be changed according to the converted unit.

2: Make sure that the setting satisfies $\frac{F \times H}{2} \leq Pu \leq F \times H \times 10000$.

3: Be sure to set up a value such that factored pulse "OFF" duration > 1 ms.

■ Parameter List (2/2) (NOTE: Flow unit “L” written under “Description” in the following table refers to the standard setting.)

- Alarm data (Title Display: AL) NOTE: Not displayed on standard specification. (Displayed only on alarm option specified models) See (8) of this section for operation detail.

Symbol	Parameter	Description	Remarks
A1d	Alarm 1 Setting	Instantaneous flow rate value that triggers Alarm 1 (Unit:L/h)	(Decimal point depends on bP)
A1H	Alarm 1 Hysteresis	Alarm 1 Hysteresis setting (Unit:L/h)	(Decimal point depends on bP)
A1S	Alarm 1 Status	Status setting of Alarm 1	[Left digit of the setting] L: Low Alarm, H: High Alarm [Right digit of the setting] S: Transistor ON during Alarm, O: Transistor OFF during Alarm
A2d	Alarm 2 Setting	Instantaneous flow rate value that triggers Alarm 2 (Unit:L/h)	(Decimal point depends on bP)
A2H	Alarm 2 Hysteresis	Alarm 2 Hysteresis setting (Unit:L/h)	(Decimal point depends on bP)
A2S	Alarm 2 Status	Status setting of Alarm 2	[Left digit of the setting] L: Low Alarm, H: High Alarm [Right digit of the setting] S: Transistor ON during Alarm, O: Transistor OFF during Alarm

- Analog trim (Title Display: AnA.tri.) NOTE: Displayed only on meters with analog output capability. See (6) of this section for operation detail.

Symbol	Parameter	Description	Remarks
A04	Analog Output 4mA trim	Analog 4mA output calibration mode (Unit:mA)	Calibrated at the time of shipment. Normally unused.
A20	Analog Output 20mA trim	Analog 20mA output calibration mode (Unit:mA)	

- Simulated output (Title Display: LooPtEst) ※ See (7) of this section for operation detail.

Symbol	Parameter	Description	Remarks
S.b	Simulated instantaneous flow rate	Set the value of instantaneous flow rate for simulated output	Set these parameters when performing loop test and etc.
S.c	Simulated total flow	Set the value of total flow rate for simulated output	
StArt	Simulated output	Execute simulated output based on the conditions set for parameters S.b and S.c	

- Service mode (Title Display : 88888888) NOTE: These parameters are for use by OVAL service personnel.

Symbol	Parameter	Description	Remarks
I.Fr	Input frequency display	Displays frequency of flow signal detected (Unit: Hz)	These parameters are for confirming the state of device and not for setting.
O.t	Operating time	Accumulated operating time since the time of shipment (Unit: time)	
F.t	Flow operating time	Accumulated flow operating time since the time of shipment (Unit: time)	
SWM	No. of times MODE button is pressed	Shows how many times MODE button has been pressed (Unit: number of times)	
SWR	No. of times RESET button is pressed	Shows how many times MODE button has been pressed (Unit: number of times)	For this Flowpet, only the wireless output type is set to “on.”
ES.bt	Energy Save Mode setting	By setting this mode to “on,” the LCD display will turn off and power consumption will be reduced for battery powered models when an operation has stopped for a certain period of time.	
FC.r	Factory reset	Reset all parameters to the factory setting value	
SoFt.	Software revision	For factory use	This parameter is for confirming the state of device and not for setting.

(3) Parameter Setup Procedure

With MODE and RESET buttons in the display, you can set up parameters.

A diagram to show parameter setup flow

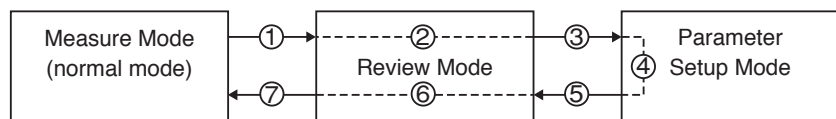

NOTES:

1. For details of button operation in steps ①, ②, ③, ⑥, and ⑦, see (4) Menu Trees and Button Operation.
2. Throughout the text in this instruction manual, holding the MODE and RESET buttons depressed is expressed as “turned ON”.

● Given below is the parameter setup procedure:

① In "Measure Mode (normal mode)," hold MODE button depressed for more than 5 seconds to go into "Review Mode."



② Using MODE and RESET buttons, show the parameter you want to modify.



③ Hold MODE button depressed for more than 2 seconds to go into "Parameter Setup Mode."



④ Using MODE and RESET buttons, set up the new parameter.
(For details of this operation, see (5))



⑤ Following the parameter entry, hold MODE button depressed for more than 2 seconds to go back to "Review Mode."



⑥ Using MODE and RESET buttons,
(= totAL, rAtE, AL *1), AnA. tri. (*2), LooPtESt, 88888888)

(*1) AL: Only with alarm option

(*2) AnA.tri.: Only for analog output equipped model



⑦ Hold MODE button depressed for more than 5 seconds to go back to "Measure Mode."

(4) Menu Trees and Button Operation

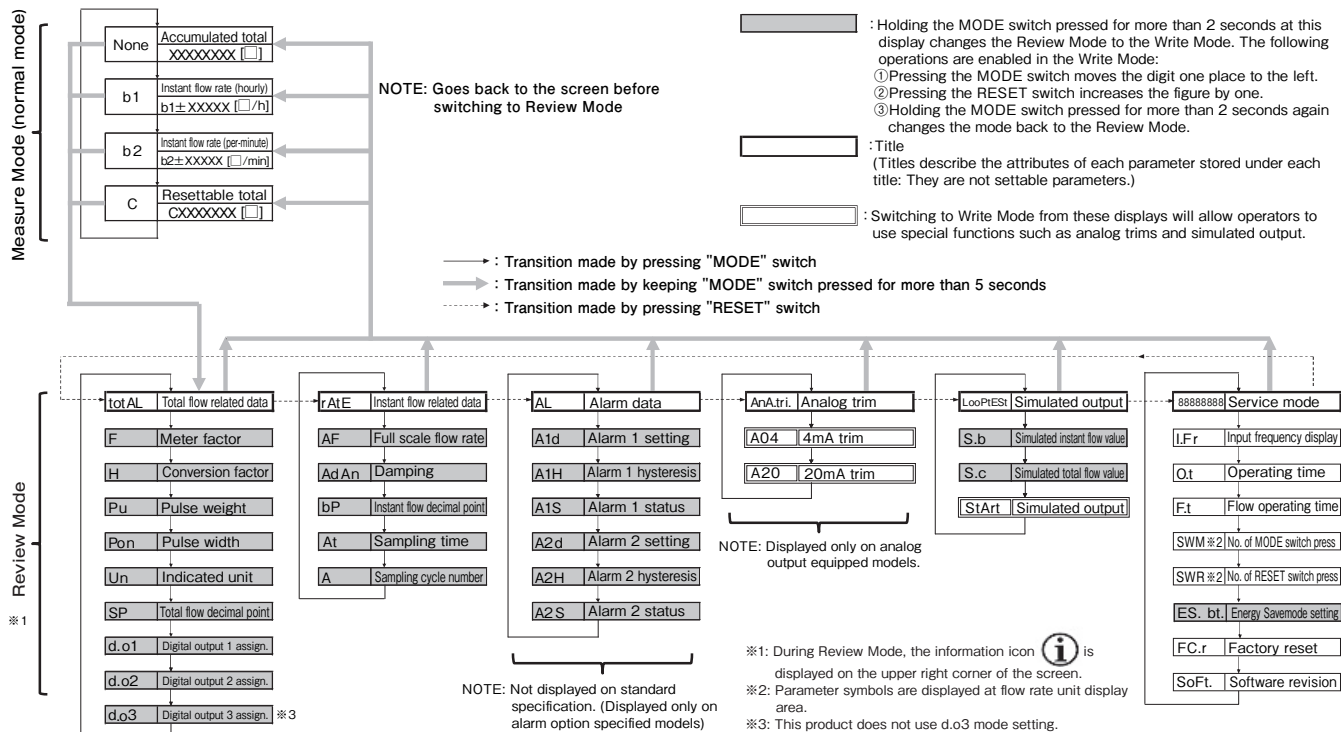

(5) The procedure to manually enter a parameter Switch operations sequence in "Parameter Setup Mode" setup, and decimal point setup) that follow:

- ① Numerical setup parameters (F, H, Pu, Pon, AF, AdAn, At, A, A1d, A1H, A2d, A2H)
The blinking digit in the parameter setup mode is the place of interest.
- MODE** ... Each time the button is turned ON, the blinking place moves one place to the left.
- RESET** ... Each time the button is turned ON, the figure in the blinking place increases by one.
Or exponential sign toggles ("E" \leftrightarrow "-").
- Following the parameter setup, hold the "MODE" button depressed for 2 seconds (the new setting is established and the screen returns to the review mode).

- ② Decimal point setup parameter (bP and SP)
In the parameter setup mode, a figure representing the decimal places of interest flickers.
- MODE** ... Not used in the setup process
- RESET** ... Each time the RESET is pressed, the decimal point moves one place to the left and the figure increases by one.
- When the decimal point appears at the desired location, hold the MODE button depressed for 2 seconds (the new setting is established and the screen returns to the review mode).

comes in three ways (numerical setup, units

Example: Parameter: F (meter factor)

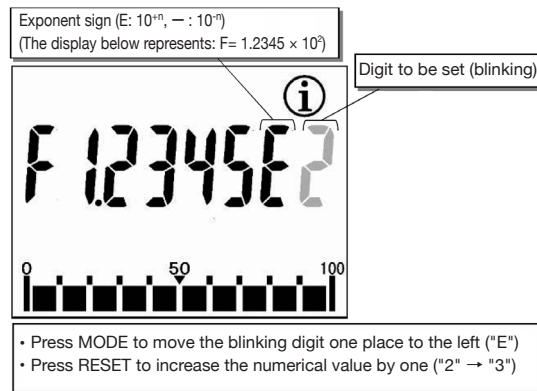

Example: Parameter: bP (instant. flow decimal point)

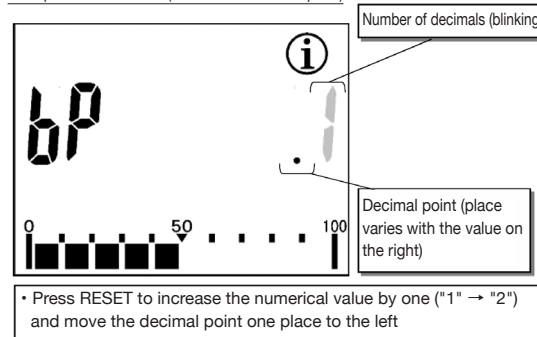

③ Item selection parameters (Un, d.o1, d.o2, d.o3, A1S, A2S)

In the parameter setup mode, the flickering part of a display indicates an item subject to change.

MODE ... Each time MODE is pressed, the decimal point moves one place to the left (applicable only to A1S and A2S).

RESET ... Each time the RESET is pressed, the displayed item changes to the next available item.

→ When the desired item for the parameter is displayed, hold the MODE button depressed for 2 seconds (the new setting is established and the screen returns to the review mode).

Example: Parameter: Un (indicated unit)

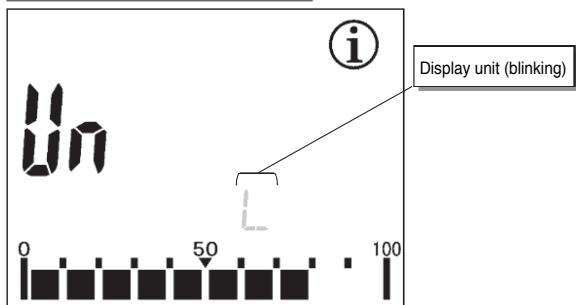

• Each time RESET is pressed, the displayed item changes to the next available item such as:
[mL→L→kL→m³→gal→ft³→g→kg→t→lb→none]

Example: Parameter: d.o1 (digital output 1)

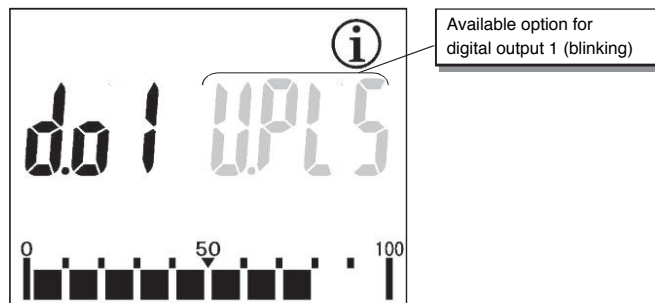

• Each time RESET is pressed, the displayed item changes to the next available item such as:
[U.PLS→PLS→AL.1→AL.2→ no output (display: ----)]

(6) Analog output trim procedure



Analog output trimming (calibration of analog output characteristics) is performed at the time of shipment; there is no need to perform this procedure under normal circumstances.

Example: 4mA trim procedure

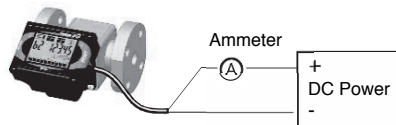

[STEP1] Preparation

- ① Set up an ammeter (or voltmeter) to monitor analog output.

[STEP 2] Begin 4mA simulated output

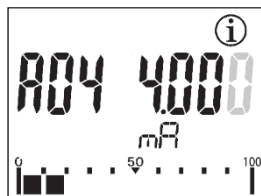

- ① Press MODE button for 2 seconds while [A04 4.000] is displayed
 → The setting (far-right "0") starts blinking and 4mA simulated output begins.
- ② Once output becomes stable, read the ammeter value.

[STEP 3] Enter simulated output current value

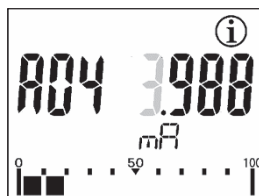

- ① Enter the ammeter reading by following the same procedure as parameter setting.
 → For example, if the ammeter reads 3.988mA, enter "3.988" as shown above.
- ② Establish the setting by pressing MODE button for 2 seconds.
 → Analog output is trimmed towards 4.000mA according to the setting.

[STEP 4] Confirm trimmed 4mA output

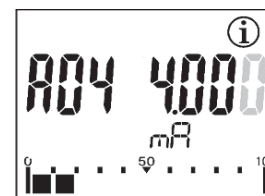

- ① Check the ammeter reading once again.
 (At this point, the display is back to [A04 4.000] with the far-right digit blinking)
- ② If the reading is acceptable for 4.000mA, press MODE button for 2 seconds to exit setting mode
 → Trimming complete (⇒ If the reading remains unacceptable, perform trimming again from procedure ④.)

→ 20mA output trim can be performed by the same procedure described above in 20mA trimming mode (A20).

(7) Simulated output function (LooPtEst)

In the parameter review mode, simulated output can be performed by specifying "Instantaneous flow rate (S.b)" and "Total flow (S.c)" then executing "StArt".

Simulated output is calculated from parameters such as Meter factor, Pulse weight, Analog full scale, etc., based on "Instantaneous flow" setting.

Signals subject to simulated output

- SIG.1 and SIG.2: Unfactored pulse, Factored pulse, Alarm 1, or Alarm 2 (depends on d.o1 and d.o2 settings)
- Analog output

(NOTE)

- Simulated output does not affect actual measured values (accumulated total mode and resettable total mode)
- Due to the capability of simulated output (frequency resolution), instantaneous flow rate (S.b) value may automatically changed to a value available for simulated output that is closest to manually set value.
- Although simulated output function is available while there is actual flow, the actual flow will not be measured by the register.

Example: Simulated output performed for 1800L/h, 100L

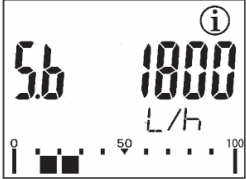
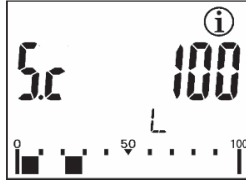
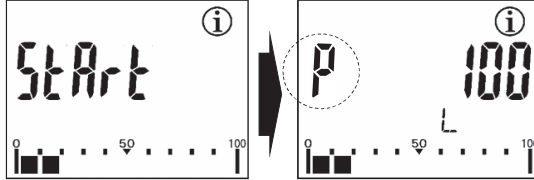
<p>[STEP1] Simulated instant flow rate setting</p>  <ol style="list-style-type: none"> ① In the parameter review mode, display the item "S.b" and press MODE button for 2 seconds. ② As the display starts blinking, enter 1800[L/h] following the same procedure as parameter setting. ③ Establish the setting by pressing MODE button for 2 seconds (blinking stops). → Press MODE button once and move to "S.c" 	<p>[STEP2] Simulated total flow setting</p>  <ol style="list-style-type: none"> ① In the parameter review mode, display the item "S.c" and press MODE button for 2 seconds. ② As the display starts blinking, enter 100[L] using the same procedure as parameter setting. ③ Establish the setting by pressing MODE button for 2 seconds (blinking stops). → Press MODE button once and move to "StArt" 	<p>[STEP3] Begin simulated output</p>  <p style="text-align: center;">↑ Hold down MODE button</p> <ol style="list-style-type: none"> ① In the parameter review mode, display the item "StArt" and press MODE button for 2 seconds. ② Simulated total flow setting (100) established in [STEP2] will be displayed indicating that it is ready for simulated output. ③ Simulated output starts by pressing RESET button once, and the total counts down to zero (during simulated output, "P" on the left hand blinks). → Pressing MODE button once during simulated output pauses the process (Press RESET button to resume). ④ Simulated output is complete when the count reaches zero. <ul style="list-style-type: none"> • To run simulated output again with the same setting → continue from ③ • To finish simulated output procedure, press MODE button for 2 seconds to go back to ① (StArt)
---	---	---

(8) About alarm output function (optional)

[Alarm related parameters and their meaning]

Parameter Symbol	Parameter	Description
A 1 d □□□□□□	Alarm 1 Setting	Alarm flow rate setting for Alarm output 1 (Set as per-hour flow rate)
A 1 H □□□□□□	Alarm 1 Hysteresis	Hysteresis for Alarm output 1 (Set as per-hour flow rate) Threshold between alarm setting value and the value at which the alarm is canceled
A 1 S △○	Alarm 1 Status	Output status of Alarm output 1 △ : High alarm or Low alarm setting Set at "H" → High alarm, Set at "L" → Low alarm ○ : State of external output during alarm (MOSFET/open drain output) Set at "S" → Short (. . . contact "Close") Set at "O" → Open (. . . contact "Open")
A 2 d □□□□□□	Alarm 2 Setting	Alarm flow rate setting for Alarm output 2 (description is same as A1d)
A 2 H □□□□□□	Alarm 2 Hysteresis	Hysteresis for Alarm output 2 (description is same as A1H)
A 2 S △○	Alarm 2 Status	Output status of Alarm output 2 (description is same as A1S)

- When the instantaneous flow rate exceeds (or falls below) the alarm setting, an ALARM icon will be turned on and external alarm output signal will be generated.
- Hysteresis can be set for alarm.
- There are 2 points for alarm: Alarm 1 and Alarm 2. These can be set individually.

⚠ (CAUTION)

If not intending to use alarm function, "0" must be set for A1d and A2d.

→ By setting "0" for A1d or A2d, each alarm function will be disabled.

For example: If A1d=500, A1H=5, A1S=LS, A2d=1000, A2H=10, A2S=HO

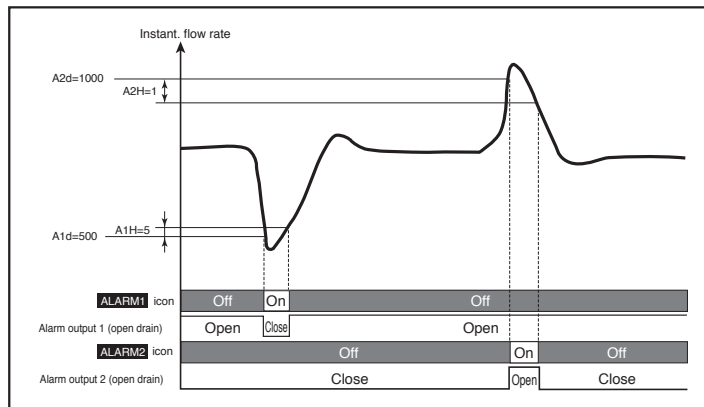

12. GENERAL SPECIFICATIONS

(1) Flow Range

Meter Size	Nominal Dia. mm		Water Service L/h	Oil Service L/h		
	Water Service	Oil Service		Kerosene	Light Oil (A Heavy Oil)	Heavy Oil
49	—	20	—	10 (20) to 800	7 (14) to 800	5 (10) to 800
50	—	20	—	150 (300) to 1600	80 (160) to 2000	50 (100) to 2000
52	20	25	200 to 1200	300 (600) to 3000	150 (300) to 3800	80 (160) to 3800
53	25	40	600 to 3600	600 (1200) to 5000	300 (600) to 6400	150 (300) to 6400
55	40	40	1200 to 7200	1200 to 11000	600 to 14000	400 to 14000
56	50	50	2000 to 12000	2000 to 20000	1400 to 24000	900 to 24000

★ NOTE Kerosene: 0.8 to 2mPa*s, Light Oil: 2 to 5mPa*s, Heavy Oils: 5 to 200mPa*s
Values in parenthesis represent the minimum flow rate of the high temperature model.

(2) Meter Body

Item		Specifications	
Application fluid		Liquid	
Application		Water service	Oil service
Accuracy		±1.0% of RD	±0.5% of RD
Operating Temperature Range (Fluid Temp.)		0 to 120°C	0 to 120°C (0 to 150°C)
Max. Operating Pressure		1.18MPa (static running water)	1.18MPa (0.98MPa)
Flange Rating		JIS 10K RF	JIS 10K RF, ASME 150 RF
Materials	Meter Body	Stainless steel	Cast iron
	Rotors	Special resin	
	Register Housing	Polycarbonate resin	
Finish	Meter Body	Not painted	Orange: Munsell 2.5YR6/13
	Register Housing	Black	

() For high temperature model.

(3) Register, Pulse Generator

Item	Description		
Display	① Accumulated total flow (8-digit) ② Instantaneous flow rate, L/h (mode: b1) ③ Instantaneous flow rate, L/min (mode: b2) ④ Resettable total flow (zero start/zero resettable, mode: C) (7-digit) } Selectable with MODE button		
Function	① Low battery alarm (Low battery indicator “  ” flickers below 3.0V) ② LCD with 7-segment, 14mm-high characters (background color: orange) ③ Flow indicator (10-segment) ④ Simulated output: set any accumulated total or instantaneous flow rate for simulated outputs (unfactored, factored, and analog) ⑤ Protection against erroneous wire connection		
Register accuracy	Total flow: ± 1 count, Instantaneous flow rate: within $\pm 1\%$ of full scale		
Display orientation	150° range in 15° steps (From horizontal position: upward 75°, downward 75°)		
Flow detection	Magnetic sensor detects alternating magnetic fields. Response frequency 200Hz max.		
Pulse output	Output type	Open drain (equivalent of open collector)	
	Capacity	Allowable current: 20mADC, Max. voltage applied: 30V	
	Pulse type	Factored	Unfactored
	Pulse width	1ms, 50ms, 100ms, 250ms (*1)	2ms (fixed)
Alarm output (optional)	Output type	Open drain (equivalent of open collector)	
	Capacity	Allowable current: 20mADC, Max. voltage applied: 30V	
	Alarm output point	Up to 2 points ("High alarm instant flow rate" or "Low alarm instant flow rate" can be set with any value for each output point)	
Analog output	4 to 20mADC (load resistance: see Section 5.3 "acceptable load resistance range")		
Cable	1 meter of vinyl-sheathed, 4-conductor (individual elements 0.25mm ² , ϕ 6.3 O.D.) cable furnished (standard) (Not furnished with models without output capability)		
Transmission distance	1 kilometer max. (when CVVS: 1.25 to 2.0mm ² cable is used) If using both analog output and pulse/alarm output, the transmission distance is 100m max. (when CVVS: 1.25 to 2.0mm ² cable is used)		
Power source (*2)	Battery pack or external power source		
	Battery pack	Lithium battery: 3.6VDC 5400mAh Battery life: 8 years (varies with operating conditions) Storage life: 10 years	
	External power source	12 to 50VDC \pm 10%	Pulse output : Current capacity 10mA or more
			Analog output : Current capacity 30mA or more
Ambient temperature range	-10 to +60°C (no condensing)		
Material	Polycarbonate (black)		
Configuration	IP65 (Install under the eaves)		

*1: Adjustable with button operation within the range of 1 to 999ms in 1ms increments. Shown above are default settings.

*2: Display functions and pulse output functions can be used just with the dedicated battery pack without an external power source.

(With an external power source, there is no need to worry about the battery life. The power will be automatically switched to battery power in case of power shut-down.)
An external power source is necessary for analog output.

(4) Units of Registration, Pulse Output Units of Registration

Application	Model	Nominal dia., mm	Max. Total Reading	Factored Output Pulse		Factored Output Pulse Width ○ : Selectable				Unfactored Output Pulse	
				Pulse Unit	Output freq.	1 ms	50 ms	100 ms	250 ms	Meter Factor	Output Freq.
Water service	LS5277	20	999999.99 L	10 mL/P	33.3 Hz	○				9.918 mL/P	33.6 Hz
			9999999.9 L	100 mL/P	3.33 Hz	○	○	○			
			99999999 L	1 L/P	0.33 Hz	○	○	○	○		
	LS5377	25	9999999.9 L	100 mL/P	10.0 Hz	○	○			17.955 mL/P	55.7 Hz
			99999999 L	1 L/P	1.00 Hz	○	○	○	○		
			99999999 L	10 L/P	0.10 Hz	○	○	○	○		
	LS5577	40	9999999.9 L	100 mL/P	20.0 Hz	○				35.496 mL/P	56.3 Hz
			99999999 L	1 L/P	2.00 Hz	○	○	○	○		
			99999999 L	10 L/P	0.20 Hz	○	○	○	○		
	LS56277	50	9999999.9 L	100 mL/P	33.3 Hz	○				76.455 mL/P	43.6 Hz
			99999999 L	1 L/P	3.33 Hz	○	○	○			
			99999999 L	10 L/P	0.33 Hz	○	○	○	○		
Oil service	LS4976	20	999999.99 L	10 mL/P	22.2 Hz	○				5.928 mL/P	37.49 Hz
			9999999.9 L	100 mL/P	2.2 Hz	○	○	○			
			99999999 L	1 L/P	0.22 Hz	○	○	○	○		
	LS5076	20	999999.99 L	10 mL/P	55.5 Hz	○				9.912 mL/P	56.0 Hz
			9999999.9 L	100 mL/P	5.55 Hz	○	○	○			
			99999999 L	1 L/P	0.55 Hz	○	○	○	○		
	LS5276	25	999999.99 L	10 mL/P	105 Hz	○				9.639 mL/P	109.5 Hz
			9999999.9 L	100 mL/P	10.5 Hz	○	○				
			99999999 L	1 L/P	1.05 Hz	○	○	○	○		
	LS5376	40	9999999.9 L	100 mL/P	17.7 Hz	○				17.470 mL/P	101.7 Hz
			99999999 L	1 L/P	1.77 Hz	○	○	○	○		
			99999999 L	10 L/P	0.17 Hz	○	○	○	○		
	LS5576	40	9999999.9 L	100 mL/P	38.8 Hz	○				34.526 mL/P	112.6 Hz
			99999999 L	1 L/P	3.88 Hz	○	○	○			
			99999999 L	10 L/P	0.38 Hz	○	○	○	○		
LS5676	50	9999999.9 L	100 mL/P	66.6 Hz	○				74.483 mL/P	89.5 Hz	
		99999999 L	1 L/P	6.66 Hz	○	○	○				
		99999999 L	10 L/P	0.66 Hz	○	○	○	○			

(5) Applicable standards

Applicable standards, etc.	EN 61326-1 EN IEC63000
----------------------------	---------------------------

- ➡ (NOTES) 1. Output frequencies are those values at the maximum flowrate.
2. Hatched areas  show setup options. (Unhatched area: Default at shipment from factory)
3. Factored pulse output unit (pulse weight) or factored output pulse width marked with ○ in the table are adjustable. If you want to change the current setting, make sure of the circle ○ first and set up new parameters Pu (pulse weight) or Pon (pulse width) referring to Section 11.2 Parameter Setup Procedure.
4. Factored pulse width is adjustable in increments of 1 ms besides those marked with circle ○, however, in this case, use care to avoid bridging of adjacent pulses at max. flowrate.

13. OUTLINE DIMENSIONS

(1) FLOWPET-5G

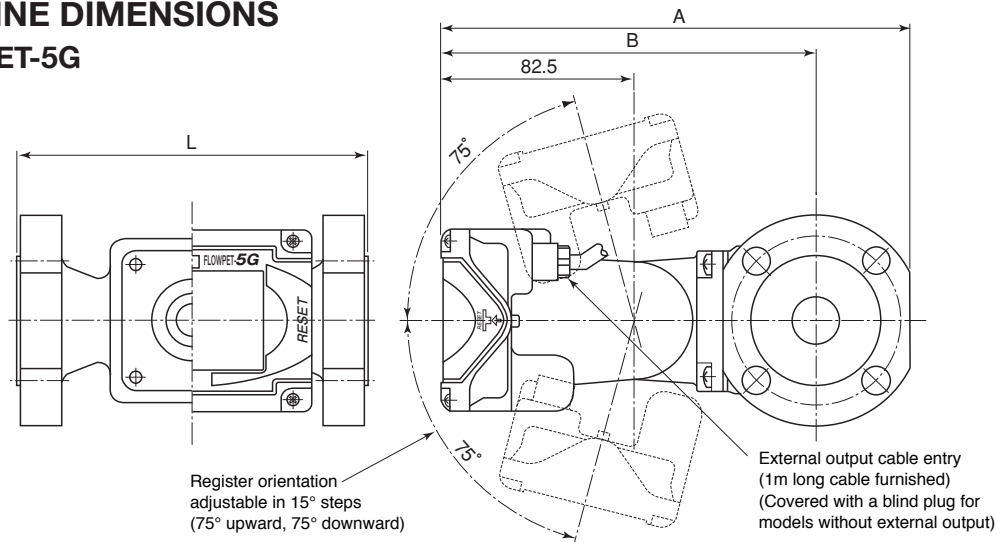

Unit in : mm

	Model	Dia.,	Nominal	L (※)	A	B	Weight kg
		Model	Dia., d				
Water Service	LS5277	20	20	225	209.5	163.5	6.4
	LS5377	25	25	225	234.5	177.5	7.9
	LS5577	40	40	245	242.5	184.5	9.7
	LS5677	50	50	280	260.5	188.5	14.6
Oil Service	LS4976	20	20	150	205.5 (235.5)	160.5 (190.5)	3.3 (3.4)
	LS5076	20	20	150	214 (240.5)	169 (195.5)	4.3 (4.4)
	LS5276	25	25	225	223.5 (248.5)	168.5 (193.5)	6.3 (6.4)
	LS5376	40	40	225	237.5 (262.5)	179.5 (204.5)	7.8 (7.9)
	LS5576	40	40	230	242.5	184.5	9.8
	LS5676	50	50	250	260.5	188.5	14.6

()For high temperature model. ※ : In the case of JIS 10K RF flange.

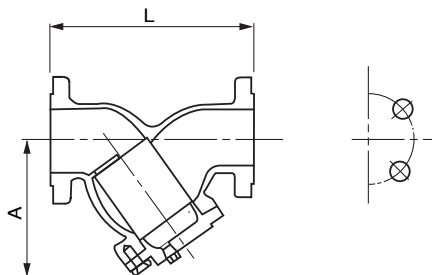
(2) Strainer

Unit in : mm

Model	Nominal Dia.	L (※)	A	Weight, kg	Net mesh	Applicable Flowpet
SS5278A	20	125	82	3.4	80	LS4976, LS5076 LS5277
SS5378A	25	140	104	5.3	60	LS5377, 5276
SS5578A	40	170	129	7.7	60	LS5577, 5376, 5576
SS5678A	50	190	153	9.6	60	LS5677, 5676

※ : In the case of JIS 10K RF flange.

14. KC Mark

Model

Item	Product code					Description
	①	②	③	-	④	
Model	L	S	5			Flowpet-5G
Power Supply					B	Battery type
					D	External power supply

Equipment Class: Class A for Office Use

사용자안내문

이 기기는 업무용 환경에서 사용할 목적으로 적합성평가를 받은 기기로서
가정용 환경에서 사용하는 경우 전파간섭의 우려가 있습니다 .

All specifications in this instruction manual are subject to change without notice for improvement in performance and product quality.

2025.12 Revised △
2015.11 Released
S-179-6-E (1)



OVAL Corporation

Phone. 81-3-3360-5121 Fax. 81-3-3365-8605