



INSTRUCTIONS

Ins. No. B-320-2-E

Batch controller equipped ULTRA OVAL

Meter Sizes: 28, 29, 31 and 60

Register Model: LW76E (two-step open/two-step shutoff)

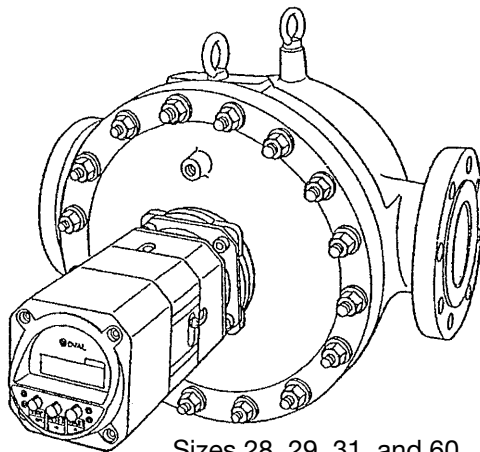

Sizes 28, 29, 31, and 60
Double Case Construction

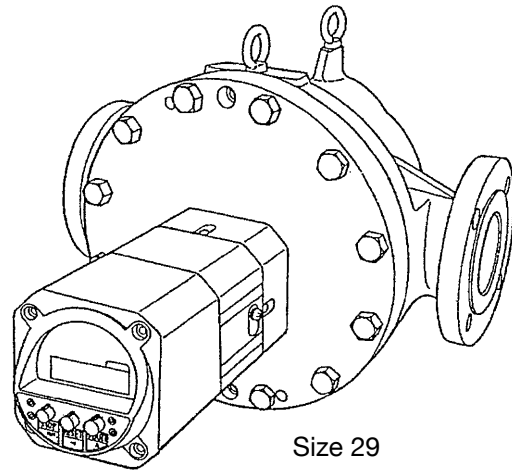

Size 29
Single Case Construction

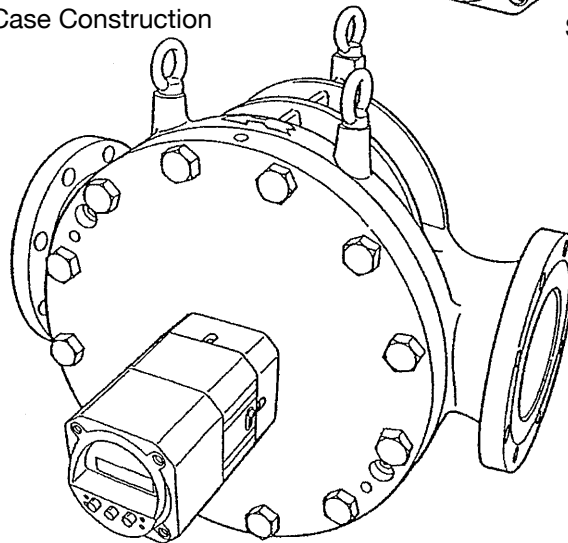

Sizes 60 and 31
Single Case Construction

Every OVAL flowmeter is fabricated, inspected, and tested under stringent quality control prior to shipment from the factory. In order to maintain its design performance throughout its life, this manual offers the operator the necessary instruction, operation and maintenance information. Be well familiar with these instructions before you place the meter in service and keep this manual at the field location for ready reference.

◆ About Meter Size Designation ◆

The size of OVAL positive-displacement flowmeters is basically identified by a two-digit code.

CONTENTS

1. BEFORE YOU BEGIN	4
1.1 Confirming the Nameplate	4
1.2 Transportation Considerations	4
1.3 Storage Considerations	4
1.4 Operating Precautions	5
2. OPERATING CONDITIONS.....	6
3. GENERAL	6
3.1 General Description	6
3.2 Features and Functions.....	7
3.3 Part Name	8
3.4 About Safety Features.....	9
4. FLOWMETER INSTALLATION.....	11
4.1 Considerations at Installation.....	11
4.2 Standard Installation, Horizontal Line	12
4.3 Standard Installation, Vertical Line	12
4.4 Example of Incorrect Installation.....	12
4.5 How to Change Display Orientations (changing flow directions).....	12
5. AIR SIGNAL LINE CONNECTIONS.....	13
5.1 System Configuration with LW76E Register Equipped Meter (1-step open/2-step close or 2-step open/2-step close).....	13
5.2 Air Signal Line Connections	13
5.3 Operation Time Chart and Pneumatic Circuit	14
6. ABOUT DISPLAY AND PUSHBUTTONS	16
6.1 Display Functions.....	16
6.2 Pushbutton Inspection and Cleaning.....	17
6.3 Pushbutton Functions	18
6.4 Switch Functions.....	19
6.4.1 Selecting Add and Subtract Counter	19
6.4.2 Selecting Setup and RUN Mode.....	19
7. RECONFIGURATION	20
7.1 Establishing a Batch Setpoint	20
7.1.1 Procedure (batch setup mode)	20
7.1.2 Example of Establishing a Batch Setpoint.....	21
7.2 Parameter Setup (cumulative total, scaler factor, frequency division, initial and final settings, missing pulse detection, overshoot setting).....	22
7.2.1 Operation in the Setup Mode.....	23
8. OPERATION	24
8.1 Preparation Before Operation	24
8.2 Preoperational Checks	24
8.3 Operation with Actual Flow	25
8.4 Operating Precautions	25
8.5 Precautions at Operation Shutdown.....	26
8.6 Strainer Inspection	26
8.7 Starting a Batch Process	27
8.7.1 Preoperational Checks Before a Batch Process.....	27
8.7.2 Starting a Batch (procedure)	27
9. INSPECTION	29
9.1 Register Inspection	29
9.2 Register Disassembly	30

9.3 Meter Body Disassembly and Inspection	32
9.3.1 Single-case Construction Meter Body Disassembly and Inspection.....	32
9.3.2 Single-case Construction Meter Body Assembly Procedure.....	33
9.3.3 Double-case Construction Meter Body Disassembly and Inspection	34
9.3.4 Double-case Construction Meter Body Assembly Procedure	35
10. ABOUT THE BATTERY PACK	36
10.1 Battery Life.....	36
10.2 Battery Pack Replacement	36
11. TROUBLESHOOTING.....	37
12. EXPLODED VIEWS AND PARTS LIST	40
12.1 Size 29 Single Case Construction Meter Exploded View and Parts List	40
12.1.1 Size 29 Single Case Construction Meter Exploded View	40
12.1.2 Size 29 Single Case Construction Meter Parts List	41
12.2 Size 60 Single Construction Meter Exploded View and Parts List.....	42
12.2.1 Size 60 Single Construction Meter Exploded View.....	42
12.2.2 Size 60 Single Case Construction Meter Parts List	43
12.3 Size 31 Single Case Construction Meter Exploded View and Parts List	44
12.3.1 Size 31 Single Case Construction Meter Exploded View	44
12.3.2 Size 31 Single Case Construction Meter Parts List	45
12.4 Sizes 28, 29, and 31 Double Case Construction Meter, 10K type Exploded View and Parts List.....	46
12.4.1 Sizes 28, 29, and 31 Double Case Construction Meter, 10K type Exploded View	46
12.4.2 Sizes 28, 29, and 31 Double Case Construction Meter, 10K Type Parts List	47
12.5 Size 60 Double Case Construction Meter, 10K type Exploded View and Parts List.....	48
12.5.1 Size 60 Double Case Construction Meter, 10K type Exploded View.....	48
12.5.2 Size 60 Double Case Construction Meter, 10K Type Parts List.....	49
12.6 Sizes 28, 29, and 31 Double Case Construction Meter, 30K type (F3) Exploded View and Parts List	50
12.6.1 Sizes 28, 29, and 31 Double Case Construction Meter, 30K type (F3) Exploded View	50
12.6.2 Sizes 28, 29, and 31 Double Case Construction Meter, 30K Type (F3) Parts List	51
12.7 Size 60 Double Case Construction Meter, 30K type (F3) Exploded View and Parts List.....	52
12.7.1 Size 60 Double Case Construction Meter, 30K type (F3) Exploded View	52
12.7.2 Size 60 Double Case Construction Meter, 30K Type (F3) Parts List	53
12.8 Register Exploded View and Parts List.....	54
13. GENERAL SPECIFICATIONS	55

"NOTE", "CAUTION" and "WARNING" in this manual are to promote awareness of users and each word has meaning as follows.

 **NOTE:** Notes are separated from the general text to bring the user's attention to important information.

 **CAUTION:** Caution statements signal the user about hazards or unsafe practices which could result in minor personal injury or product or property damage.

 **WARNING:** Warning statements signal the user about hazards or unsafe practices which could result in severe personal injury or death.

1. BEFORE YOU BEGIN

Every ULTRA OVAL with a batch control feature is thoroughly tested before it leaves the factory. When received, it should be thoroughly inspected for indication of rough handling during transit. Necessary handling precautions are described in this section; read the instructions carefully. As for other information, find the respective sections from "CONTENTS" on pages 2 and 3.

For any inquiries, contact your nearest OVAL sales office.

⚠ CAUTION: When you make inquiries, include the product name, model number, product number, ratings and other pertinent information.

1.1 Confirming the Nameplate

Every Ultra OVAL is assembled and adjusted according to individual specifications.

Product code number and ratings are stated on the register nameplate. Make sure that, the ratings shown conform to your particular specification.

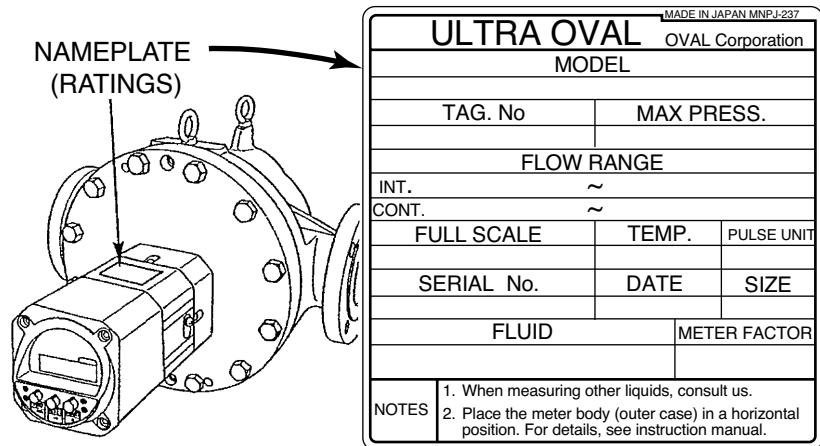

1.2 Transportation Considerations

- (1) To safeguard against damage during transit, transport the Ultra OVAL to the installation site in the same container used for transportation from the factory if circumstances permit.
- (2) Ultra OVAL is adjusted and inspected as an assembly consisting of the meter body, sensor and register. It should therefore be handled as an integral assembly.
- (3) The register is accurately configured and adjusted. Do not remove its front cover to gain access to its internal assembly except for reconfiguration.

1.3 Storage Considerations

If your Ultra OVAL is stored for long periods of time upon receipt before installation, unexpected faulty conditions could result. If a long-term storage is anticipated, take the following precautions:

- (1) Keep the Ultra OVAL in store in the same shipping container used for transportation from OVAL if possible.
- (2) Place of storage should conform to the following requirements:
 - Free from rain and water.
 - Free from vibration and impact shocks.
 - Temperature and relative humidity in the storage place are at or near room temperature and humidity (around 25°C and 65%).
- (3) Purge the Ultra OVAL that has once been placed in service with clean air, N₂ gas, etc. to prevent the metered fluid from adhering to the meter connections, piping inner walls, housing, etc. before storage. (Wash clean with suitable detergent if necessary.)
- (4) In case of storage for extended periods of time, good practice is to remove the battery pack from the register.

➡ NOTE: See Sec. 10.2 "Battery Pack Replacement" on page 36.

1.4 Operating Precautions

(1) Operating precautions to be observed

- 1) Do not attempt to change component parts or modify circuits of the register.
- 2) Do not paint out the warning label or remove warning and specification labels printed or attached to the register. Applying a coat of paint to synthetic resin components, such as pushbuttons, may possibly result in malfunction of the affected components by the solvent it contains.
- 3) Since the solenoid valve to control the operation signal of the shutoff valve installed in the flowmeter register is of an internal pilot type, proper switching of the signal may be hindered if the supply air pressure connected to "IN" port of the solenoid valve unit falls below 0.20MPa.
For this reason, do not use it for controlling an emergency shutoff valve or similar equipment.
- 4) To prevent accident possibly caused by the failure of the flowmeter counter or continuous flow valve of this flowmeter, be sure to install a safety valve such as manual valve in the OUT side piping of the continuous flow valve. The safety valve must be closed when the flowmeter is not in operation.

(2) About the quality of air source (fluid for actuating the shutoff valve [air, nitrogen, etc.]

(See JIS B 8370 "Guidelines to Pneumatic Systems.")

- 1) Avoid using compressed air that contains synthetic oil with chemicals or other organic solvent, sodium, corrosive gas, etc. which may cause component parts failure or malfunctioning.
- 2) Use clean, dry air that does not condensate at operating temperatures in the environment where the product is placed in service.
Provide an air filter at the air source (filtration accuracy 5 μm approx. or finer).
- 3) Supply pressure to the flowmeter register is 0.20 to 0.69MPa. Adjust the pressure to somewhere in this range with reducing valve or similar regulator.
- 4) A solenoid valve to control the operation signal of the shutoff valve is incorporated in the flowmeter register.
Large quantities of drain may cause malfunctioning of the solenoid valve and other pneumatic equipment used besides environmental pollution. Careful considerations must therefore be made in handling of drain. In case such handling is difficult, good practice is to provide an auto drain equipped filter.
- 5) Powder carbon produced from the compressor can build up on valve interior in quantities leading to valve malfunction. To get around this problem, select a compressor oil that produces less powder carbon and/or provide an oil mist separator.

(3) About the operating environment

In low temperature applications, due precautions should be taken against solidified or frozen drain or water inside the solenoid valve. In a case like this, we recommend to provide a dehumidifier, such as a dryer, to remove fluid to be drained and water content.

➡ NOTE: The above mentioned compressed air purification equipment are available from OVAL as an option.

(4) About piping

1) Preparation for installation

Prior to installation, thoroughly remove construction debris, such as metal chips, cutting fluid, and other foreign matter remaining in the piping system by air blow (flushing) or cleaning.

2) Wrapping the seal tape

When screwing in pipes and fittings, exercise care to preclude metal chips produced in pipe screw-thread cutting and fragments of seal tape from entering the valve. If thread seal tape is used, leave 1.5 to 2 threads to remain unwrapped.

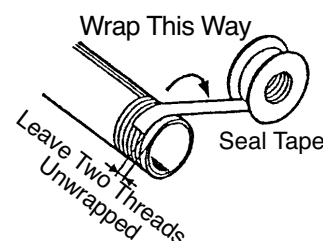

3) Before making pipe connections

Refer to the instruction manual to ensure that pipes are connected to the right ports.

4) For air supply to actuate shutoff valve, use $\phi 6 \times \phi 4$ copper tubes.

(5) About maintenance and inspection

(Refer to JIS B 8375 "4- and 5-port Pneumatic Solenoid Valves".)

In order to ensure normal operation of the register, do not fail to test it by pressing the start/stop button of the register alternately several times without flowing the process fluid. This test will indicate whether the solenoid valve in the register works properly or not.

2. OPERATING CONDITIONS

To maintain the stated high accuracy and long service life of the Ultra OVAL, make sure that flowrate, pressure, temperature and viscosity are within the ratings as stamped on the meter register tag (page 4).

CAUTION

- (1) Although allowable ambient temperature is up to +60°C for explosionproof units, it is desirable that the meter be used at room temperature and humidity.**
- (2) In cases where the register is exposed to elevated temperatures due to exposure to direct rays of the sun or to radiant heat, ensure, by providing a sunshade or similar protection, that the meter is used within the operating temperature range (-10 to +60°C).**
- (3) Avoid such installation locations as:**
 - 1) hardly accessible for maintenance and inspection.**
 - 2) temperature variation and/or vibration is excessive.**
 - 3) potential danger of immersion in water.**
 - 4) corrosive gases exist.**
 - 5) not compatible with the explosionproof construction of this meter.**
 - 6) large electromagnetic noises are highly expected.**

3. GENERAL

3.1 General Description

The Ultra OVAL is a high-precision flowmeter combined with a user friendly batch controller for use in the field. Its electronic register is programmable with front pushbuttons for batch processes (or quantities of the process fluid to be delivered). When used in combination with a pneumatic shutoff valve, you can build an automatic metering system which opens the shutoff valve upon depression of the start button and shuts it off when a preset quantity of the process fluid is reached.

The register combined with this meter is the LW76E which features a two-step open, two-step close (or one-step open, two-step close) arrangement. Applications include batch processes in chemical plants, blending, filling, or clearance processes in the food, pharmaceutical, paint, petroleum, and chemical products industries to save time and effort, streamline processes, and achieve product uniformity.

In this meter, an amorphous sensor detects the fluid flow by picking up the magnetic fields of permanent magnets embedded in the oval rotors of proprietary contoured gear profile. As a result, high reliability of achieved.

3.2 Features and Functions

(1) Long life

Absence of mechanically sliding components except for oval rotors, solenoid valve and control buttons contributes to long service life. Small wetted parts count and pocketless design makes this meter ideally suited for flow measurement of chemical liquids.

(2) Electronic register saves time and effort in metering operations.

- 1) Figures in the LCD display are 12.7mm high for easy readability.
- 2) Batch setpoint (6-digit) and cumulative total count (8-digit) are selectable with a switch for management of totals.
- 3) Front pushbuttons select the desired batch setpoint.
- 4) Add or subtract counter in the batch process is selectable (subtract counter is standard).
- 5) Advance signal can be set at any point in a range from 0 to 999 counts.
- 6) The duration of missing flow signal pulses can be set at any point from 0 to 15 seconds.
- 7) An overshoot (overmeasurement) can be set at any point from 0 to 99 counts.
- 8) Can resume a metering cycle for the remainder of a batch that has been interrupted by an emergency stop.
- 9) Can review the batch setpoint upon depression of  button while a batch cycle is in progress.

(3) Installation location

The register is of waterproof construction (JIS C 0920 Weathertight) for installation outdoors. Its intrinsically safe explosionproof construction (Exia II BT3) permits installation in hazardous locations (Divisions 0, 1, and 2 area) (explosionproof models only).

(4) Field work required

- 1) Battery powered, it eliminates the need for an external power source (field wiring not required). The built-in battery is good for four years (battery life may vary according to the operating conditions). (A low battery alarm "BATT" flickers in the front LCD when the battery is near to its end.)
- 2) Replacing the existing OVAL register (LW76) with this new model does not require another air source; the existing shutoff valve remains serviceable.

(5) Affords adequate protection in batch processes

- 1) In the model equipped with LW76E register, the shutoff valve opens and closes moderately by the initial and final flowrate control signals: the arrangement eliminates static electricity buildup in the piping assembly and in the tank at startup, and prevents hydraulic shock at valve closure.
- 2) If something erratic (missing flowrate signal, for example) occurs in the batch process, a shutoff valve closure signal is automatically generated.
- 3) The operator can monitor shutoff valve operation signals, alarmed conditions, and other status with front LCD illumination in its 1st and 8th digit segment.
- 4) In the event the battery has run down during the batch process, safety is maintained by shutting off the valve automatically. Parameters and variables are retained in the E²PROM (nonvolatile memory): you will not be required of setting them up all over again after battery pack replacement.

(6) Simplified maintenance

The electronics is of modular and printed circuit board construction, housed in a plastic casing; pneumatic circuitry (solenoid valve assembly), control buttons, and battery pack are of independent units for maximum ease of maintenance.

⇒ NOTE:

With the use over an extended period of time, meter error will deviate more or less from that in initial factory calibration. Upon request, we may conduct an instrumental error testing once again and establish a "new meter factor" in the scaler when your Ultra OVAL is returned to the factory for periodic inspection or for other reason.

3.3 Part Name

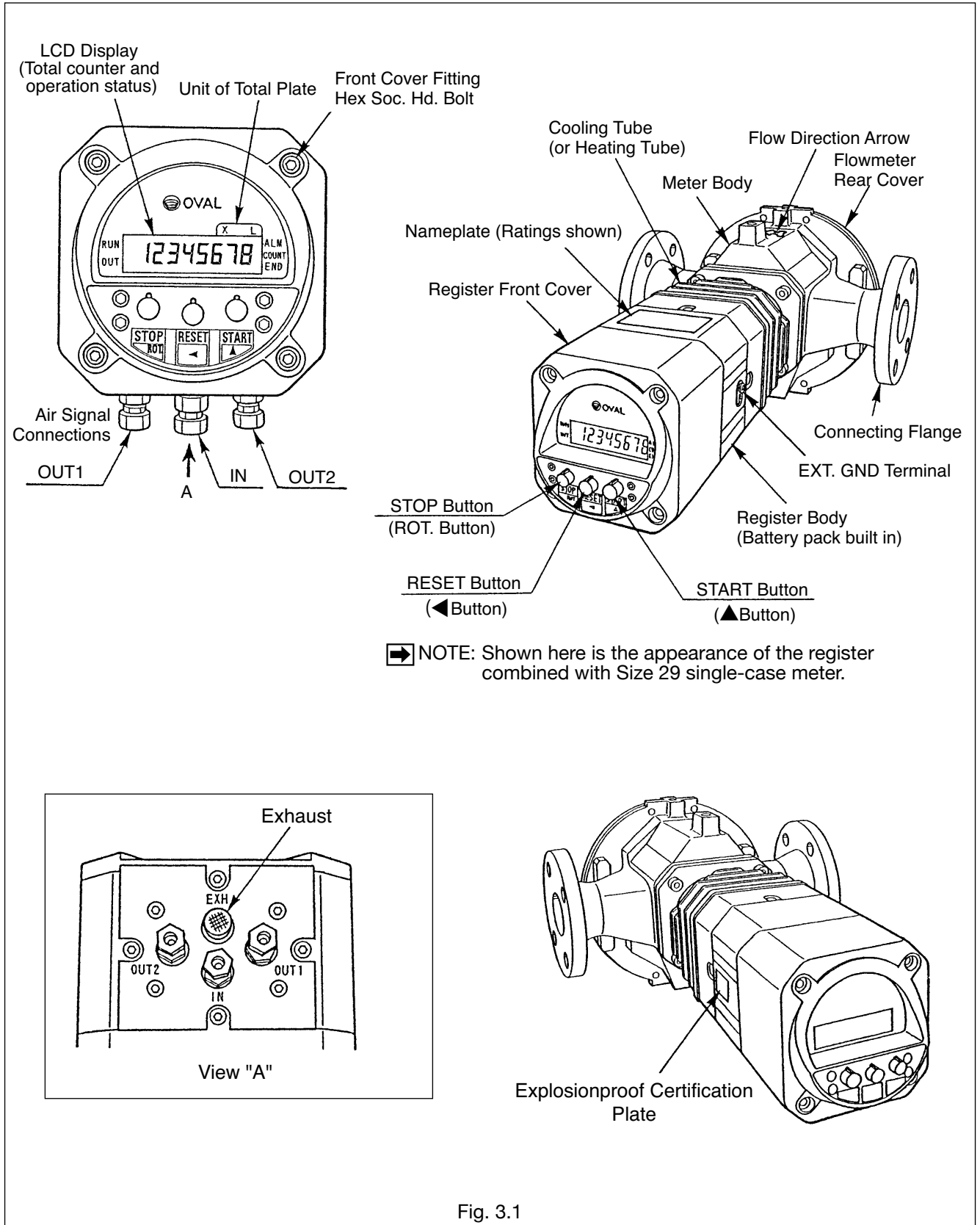

Fig. 3.1

3.4 About Safety Features

The register is provided with the following safeguards:

(1) On detection of missing pulses

Either condition 1) or 2) causes the indicator "ALM" in the display to light and the shutoff valve to close automatically for safety's sake.

- 1) The register fails to count any pulses within preset missing pulse period (PL) from the moment a batch process started.
- 2) Counting pulses is interrupted during a batch process and remains interrupted beyond preset missing pulse period (PL).

The electronics starts missing pulse detection 5 seconds from the start of a batch process; actually a missing pulse setpoint (PL) + 5 seconds is required for this function to go into effect.

Large totalizer units of measure (weights of the total count) by frequency reduction or other processing may require more time to update the count, but such a condition will not trigger a missing pulse detection alarm. If "0" is chosen for missing pulse setpoint (PL), the capability to detect missing pulses will remain disabled. For manual batch processing, therefore, we recommend you to use a setpoint at "0."

(2) On detection of an overshoot (overmeasurement)

An overshoot of measurement at the end of a batch does occur due to some time lag in shutoff valve actuation (on closure). An indicator "ALM" in the display lights when the register counts more than the anticipated overshoot count (oV).

➡ NOTE: While "0" is chosen for anticipated overshoot count (oV), the overshoot detection feature remains disabled.

(3) On detection of a low battery

A weak built-in battery tells the operator with a blinking alarm "BATT" in the display. When the battery has run down nearly to its end, the "ALM" comes on, the shutoff valve closes automatically (if in an open position) and, at the same time, the variables (total count in a batch process and cumulative total count) are evacuated to a nonvolatile memory.

From this moment onward, valve operation will remain inoperative ( button will not respond). As a

rule of thumb, it takes about 8 days from a blinking "BATT" alarm till a stay-on "ALM." It is suggested that the old battery be replaced with a new one during this period.

➡ NOTE: A low battery when left unused for some time may restore its energy to some extent and may be used for a batch job again, only for an unpredictable length of time. Do not fail to replace a battery that has once caused the "ALM" to come on.

4. FLOWMETER INSTALLATION

4.1 Considerations at Installation

- (1) The LCD display of Ultra OVAL equipped with a batch controller is designed to be seen down from upper point, rather than at the same level. Take this into consideration when you decide its installation height.

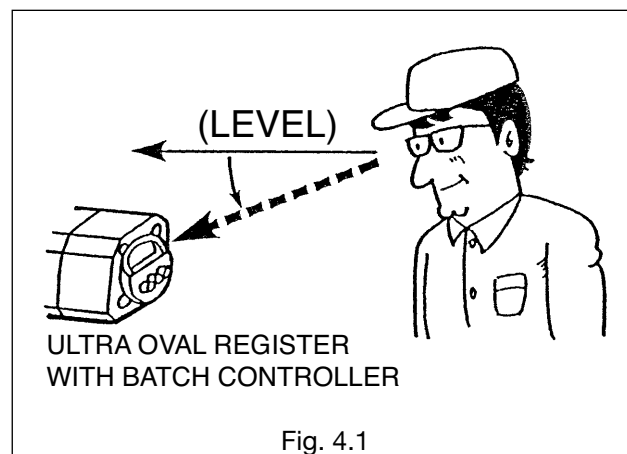

- (2) Flush the piping assembly.
Flushing must be performed before meter installation. Install a short pipe in place of the meter at this time (see Fig. 4.2 below).

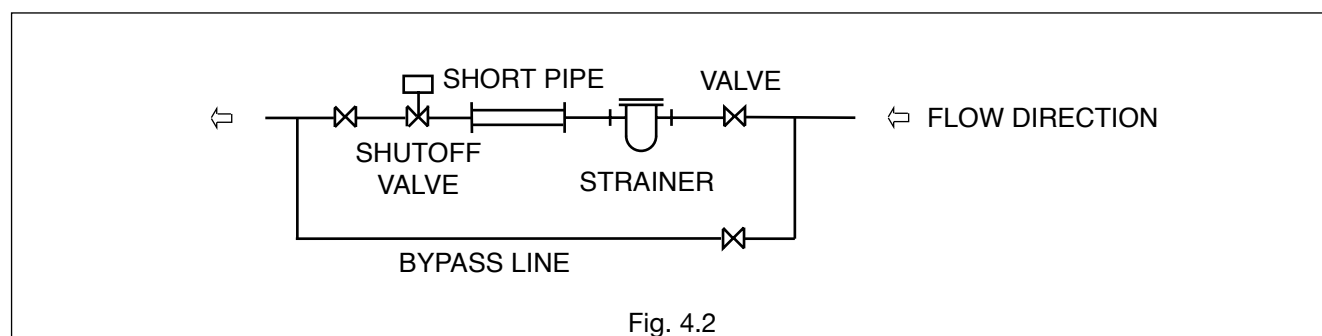

- (3) After flushing, remove the short pipe section from the pipeline and install the meter in place, exercising care to avoid any pipe strain on the meter.
- (4) The meter must be installed on the discharge side of the pump.
- (5) If the meter is to be used under tank head, give a head pressure greater than the total pressure losses of the piping system, strainer, meter, and other associated equipment.

➡ NOTE: Pressure losses of the Ultra OVAL with a batch controller and strainers are stated in the GENERAL SPECIFICATIONS.

- (6) The flow direction arrow indicated on the meter body should point in actual direction of flow.
- (7) The strainer should be located upstream of, and in close proximity of the meter.
- (8) Since the sensor in the Ultra OVAL detects the changes in magnetic flux density, it must be isolated from the influence of external magnetic fields.
In order to minimize the influence of external magnetic fields, select an installation location at least 5 meters from existing power equipment and conductors - potential sources of creating large magnetic and electric fields, such as motors and generators.
- (9) If electrical heating is considered, consult the factory.
- (10) If heat retention is desired, do not allow lagging material to cover up the meter adapter and register assembly.

● Typical examples of Ultra UF-II installation are shown on the next page.

4.2 Standard Installation, Horizontal Line

- (1) In case flow direction is from R to L, change places of meter and strainer.
- (2) Arrange piping so as to facilitate drainage.
- (3) Strainer should be inspected on a regular basis.

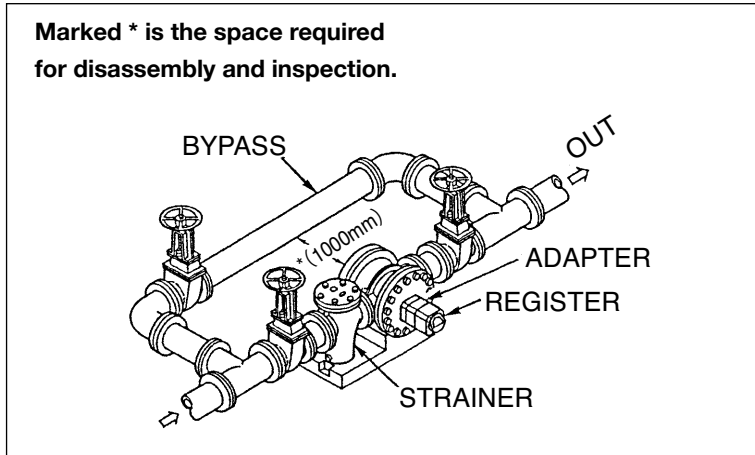

4.4 Example of Incorrect Installation

- (1) Do not install the meter in a position like this.

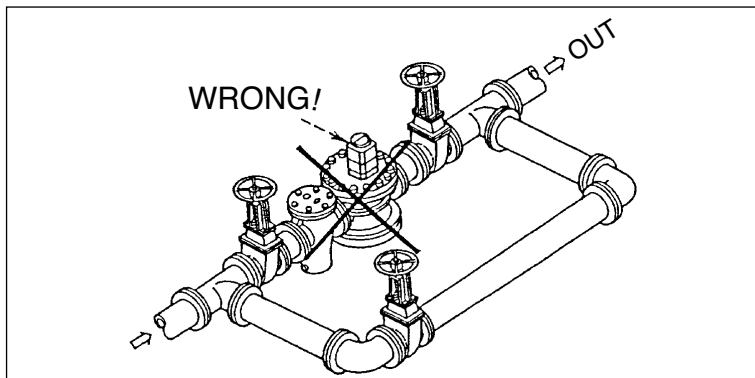

4.3 Standard Installation, Vertical Line

- (1) If the flow direction is from top to bottom, change places of meter and strainer.
- (2) Installing the strainer at "B" will make net reinstallation difficult at cleaning; we recommend to install the strainer at "A".

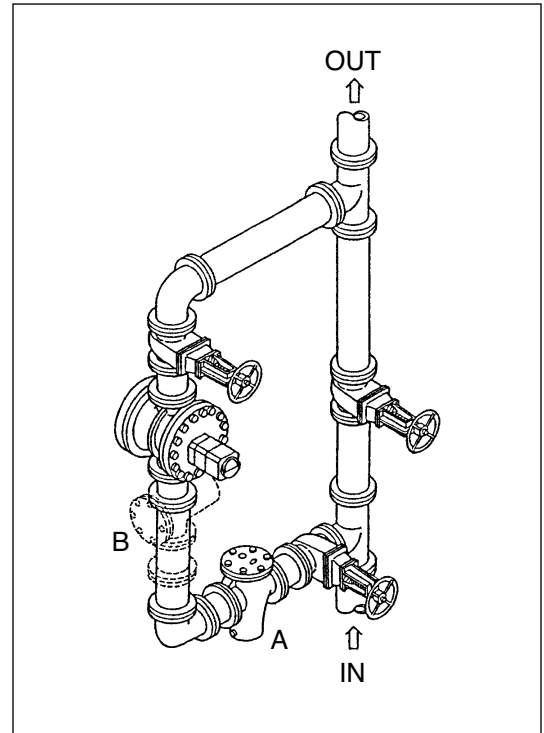

NOTE:
For outline dimensions and pipe connection dims., see approval drawing.

4.5 How to Change Display Orientations (changing flow directions)

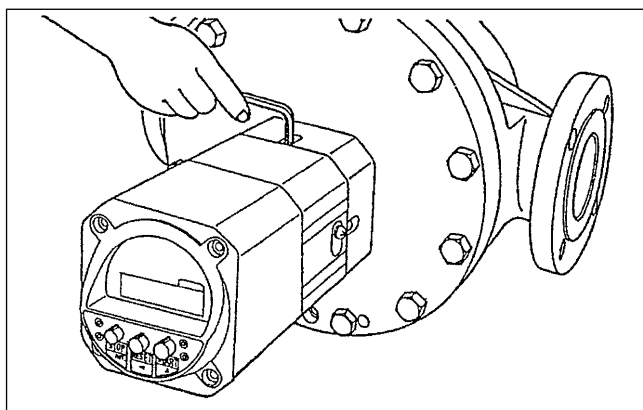

- (1) Take off four hex socket head screws (M6) with hex wrench.

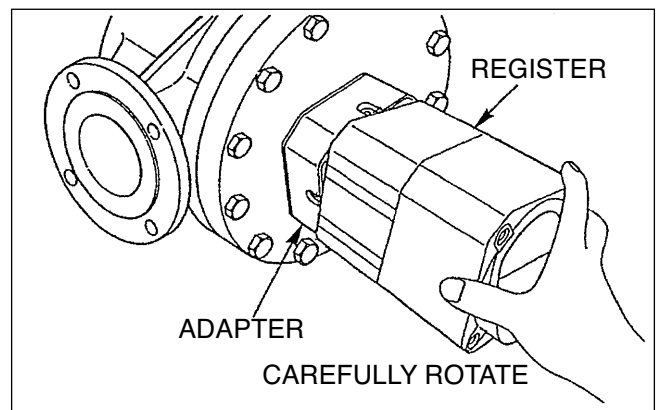

- (2) Holding the register in both hands, carefully rotate it to a desired orientation of the new flow direction, and secure it with hex socket head screws.

⚠ CAUTION Never rotate the register assembly more than one complete revolution. Do not attempt to separate the register assembly from the meter body to change the flow directions.

5. AIR SIGNAL LINE CONNECTIONS

5.1 System Configuration with LW76E Register Equipped Meter (1-step open/2-step close or 2-step open/2-step close)

➡ NOTE: For simplicity's sake, the Ultra OVAL (*) with a batch control feature is shown here in an upright position. In practice, the flowmeter should be installed in the physical orientation shown in Sections 4.2 and 4.3.

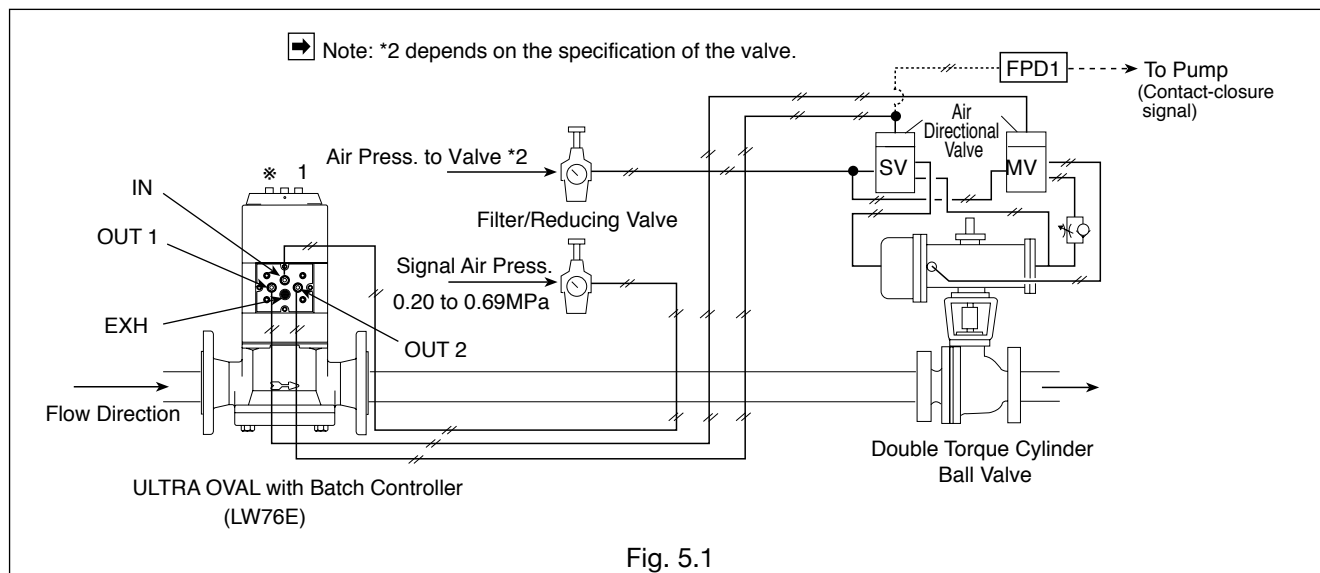

NOTE: When combined with OVAL pneumatic-electrical switch (Model FPD1), the pump can be interlocked.

For complete details, see the pneumatic-electrical switch instruction manual.

5.2 Air Signal Line Connections

The register contains a pneumatic circuits to which air signal lines of copper tubing are connected through their ports below the register body.

- Air pressure: 0.20 to 0.69MPa
(adjusted to shutoff valve specification.)
(Must be clean air)
- Air tubing diam.: Use $\phi 6 \times \phi 4$ copper tubing.
(Bite-type couplings (Rc1/8) are provided.)
- Output air connections
OUT 1: Main valve (MV) open signal
OUT 2: Small valve (SV) close signal

IMPORTANT: At the supply air connection, be sure to provide a reducing valve furnished with a filter (Model 1301-8002).

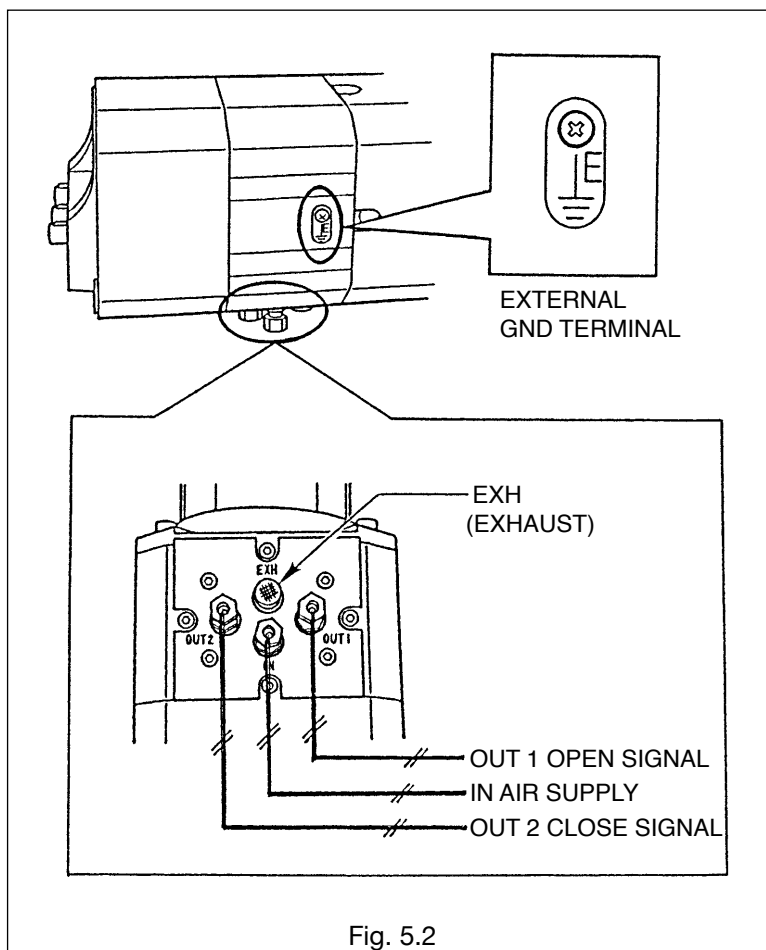

5.3 Operation Time Chart and Pneumatic Circuit

■ Description of Operation Time Chart

➡ NOTE: Operation can best be understood by referring to the chart below.

Upon depression of  button, the shutoff valve opens to a predetermined position (initial flowrate). When a predetermined quantity (from point A to point B) has been delivered, the valve opens fully; when metering has reached point C, the valve automatically throttles the flow and maintains a predetermined valve position (final flowrate).

At point D (batch setpoint), a closure signal (full closure signal) is generated.

However, due to a time lag in valve actuation, inherent to the type of valve used, the valve actually closes at point E. Since the amount from point D to point E can be anticipated (an overshoot or over measurement), we determine the right batch setpoint corrected for this overshoot. If an overshoot exceeds a predetermined quantity, the register sets off an alarm.

Safe and precise measurement is thus achieved. In practice, we preselect valve positions A → B and C → D on the part of the shutoff valve.

➡ NOTE: In a model equipped with LW76E register, manual interruption while the valve is fully open causes the shutoff valve to close in one step and, when operation is resumed for the remaining batch process, it opens up in one step.

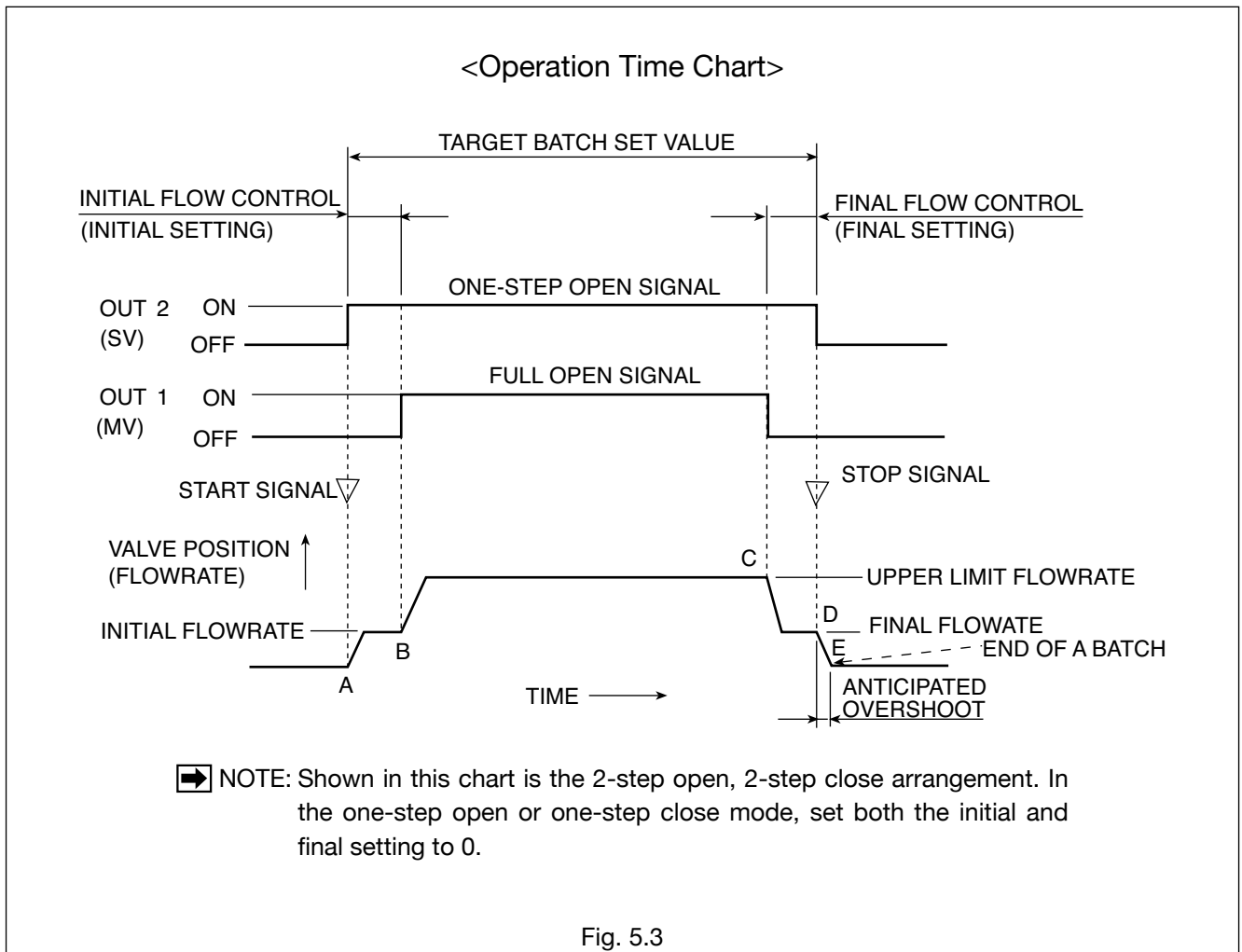

■ Pneumatic Circuit

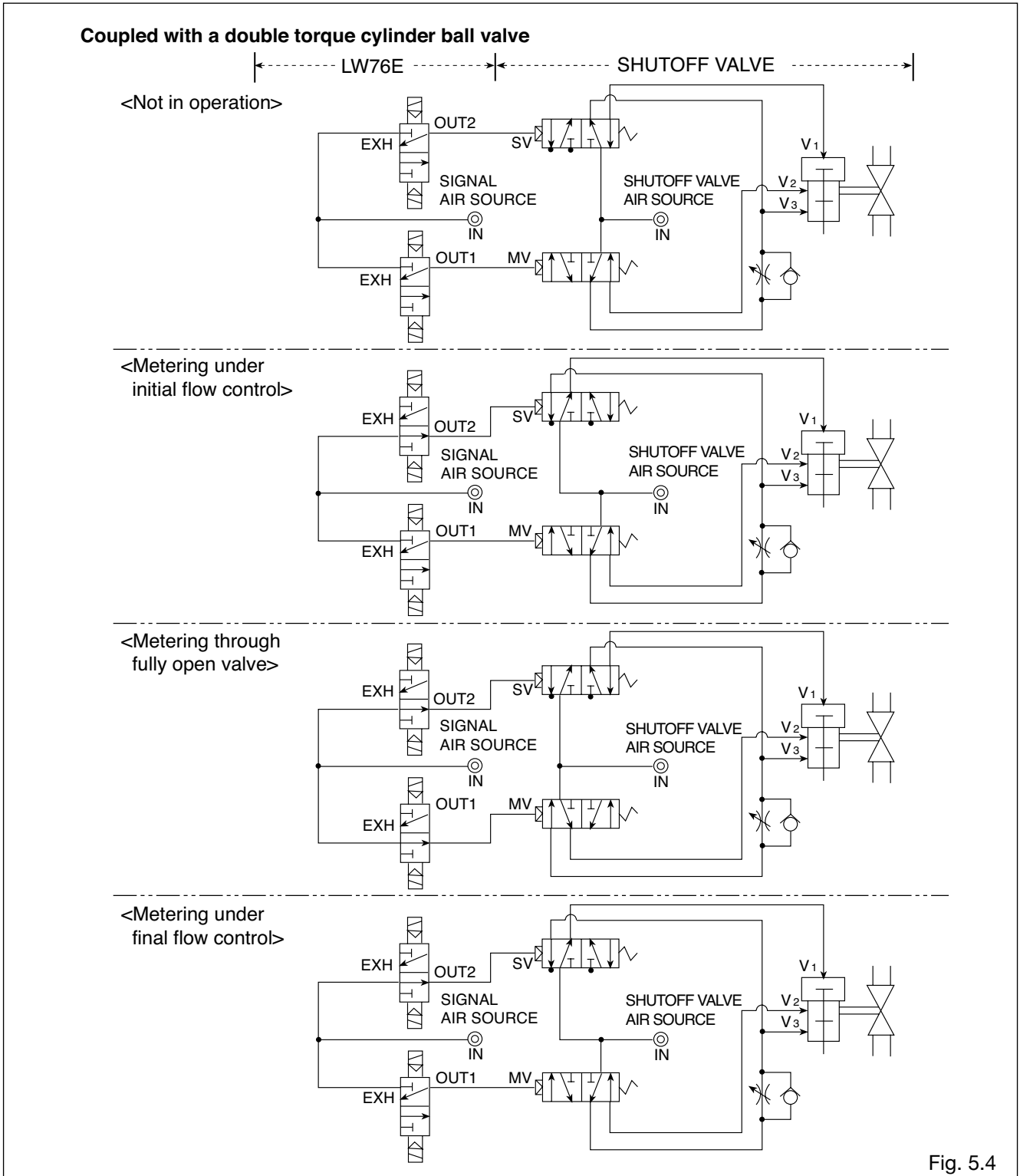

Metering Action	Output Signal		Shutoff Valve			
	OUT1	OUT2	V ₁	V ₂	V ₃	Valve position
Not in operation	0	0	0	0	1	Closed
Metering (initial flow control)	0	1	1	0	1	SV open
Metering (fully open)	1	1	1	1	0	SV, MV open
Metering (final flow control)	0	1	1	0	1	SV open

NOTE: Pressure at individual port
 0 - Air pressure not supplied
 1 - Air pressure supplied

6. ABOUT DISPLAY AND PUSHBUTTONS

6.1 Display Functions

Three pushbuttons - STOP/ROT., RESET/◀ and START/▲ - are arranged on the front for controlling a batch process and for setting parameters and variables. Located in the center of the display assembly is an 8-digit LCD to show characters 12.7 millimeters high.

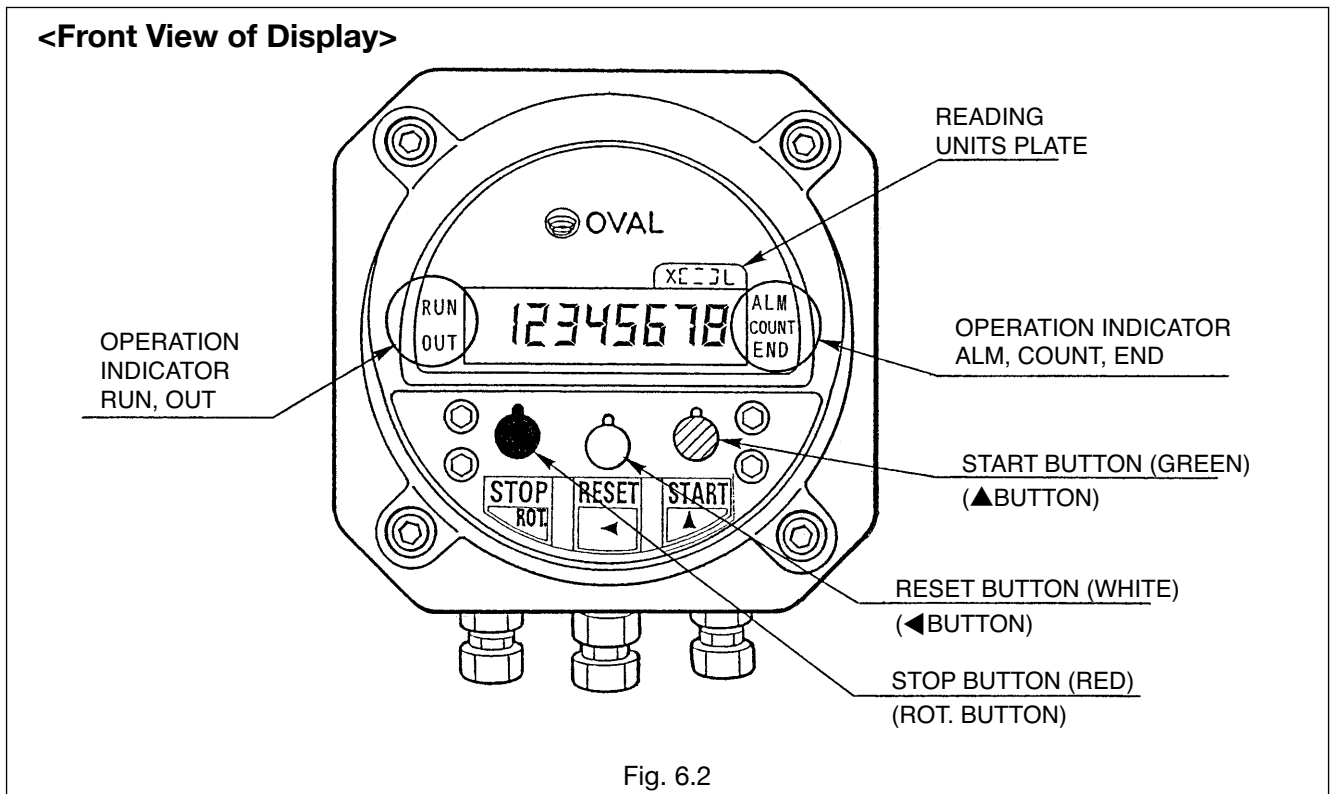
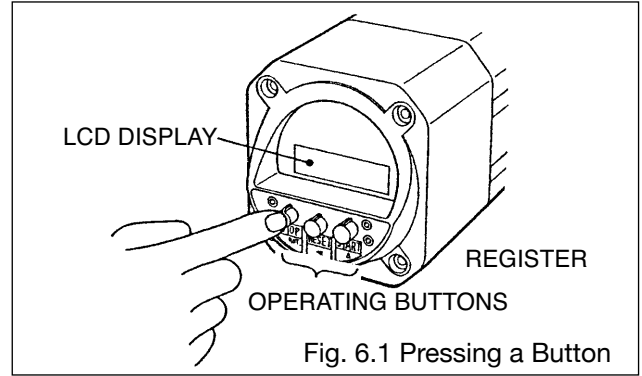

The display is provided with the following functions:

Table 6.1 Operation display function

INDICATION	DESCRIPTION	Illuminated segment (See figure on next page.)
RUN	Blinks while the register is in operation.	a
OUT	Comes on in response to a shutoff valve operation signal output (MV, SV).	b, c
ALM	Stays on (missing pulses, excessive overshoot, low battery alarm) until reset.	d
COUNT	Comes on in response to pulses incoming to the total counter (blinks in synchronism with incoming pulses).	e
END	Comes on at the end of a batch process. (Stays on until the batch setpoint is reset.)	f
BATT	Blinks to indicate a low battery.	g

➡ NOTE: For batch setup mode, see paragraph 7.1.1 in page 20.

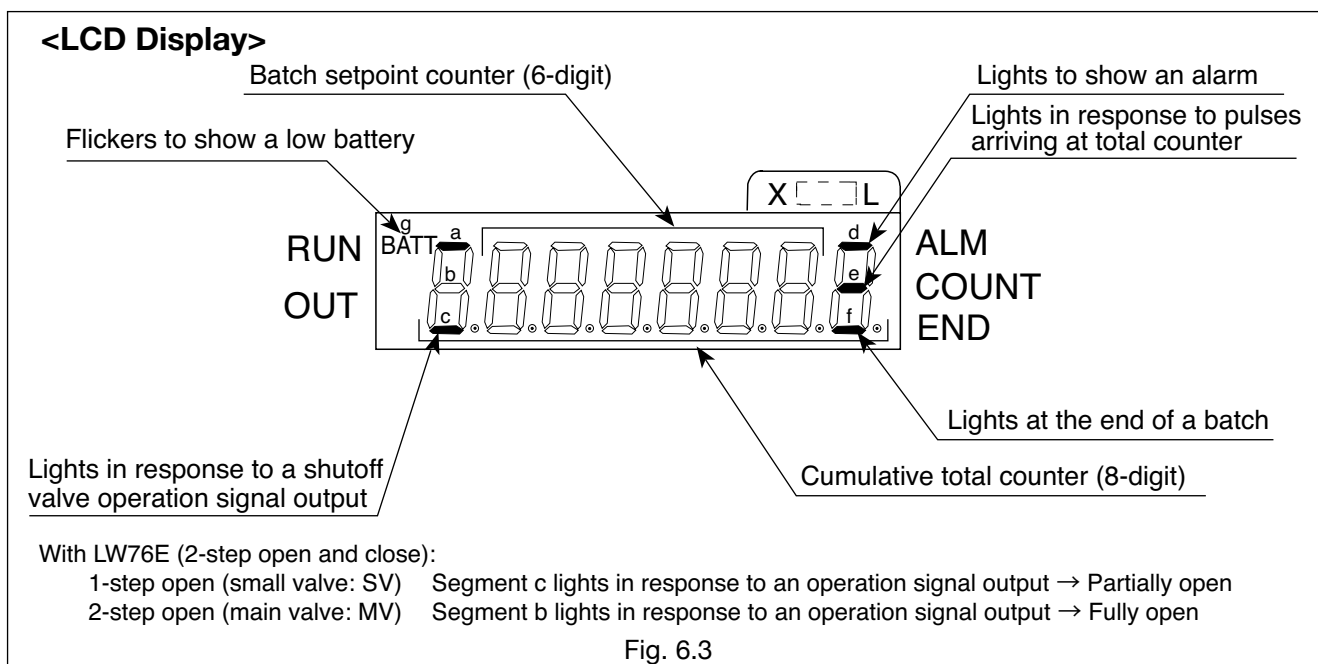

6.2 Pushbutton Inspection and Cleaning

Pushbuttons used for operation can be inspected and cleaned by first removing its semicircular panel, with the flowmeter in the pipeline or not. Be sure to depressurize the air source or remove the front cover to prevent the shutoff valve from actuation before separating the pushbutton panel.

- (1) Take off four hex socket head bolts and remove the semicircular panel (Fig. 6.4).

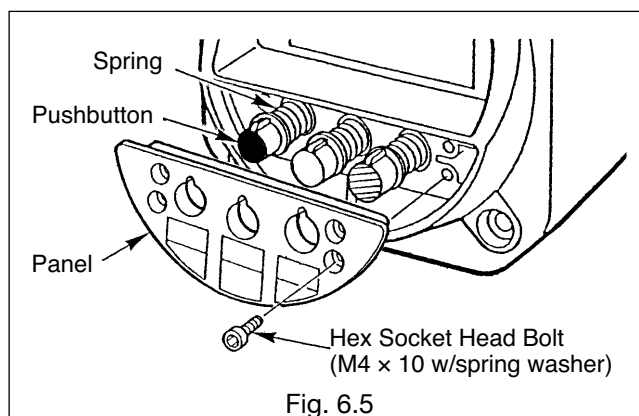
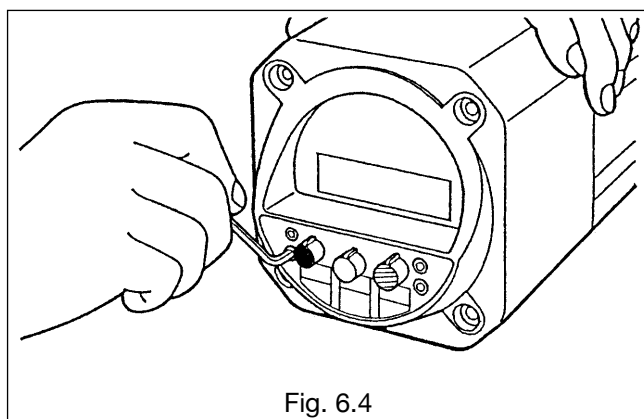

⚠ CAUTION When separating the panel, be careful to prevent pushbuttons and their springs from coming off and being lost (Fig. 6.5).

- (2) Inspect and clean pushbuttons, their springs, and button sockets on the part of the register front cover.
- (3) Following inspection and cleaning, install pushbuttons into place according to their colors. (See pushbutton colors on the previous page.)

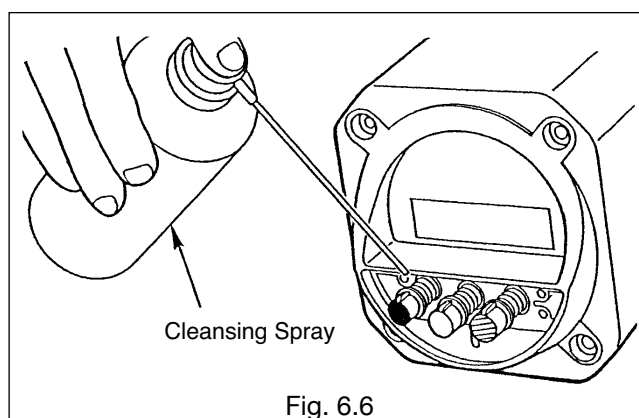

- ⚠ CAUTION**
1. The panel is made of resin. Tighten bolts at 150cN·m.
 2. Avoid immersion of the panel and pushbuttons in solvent such as thinner, as these parts are made of resin.

6.3 Pushbutton Functions

NOTE: For pushbutton switch locations, see Fig. 6.2 on page 16.

 **button (red), internal button**  **functions**

Mode of Operation		Functions
RUN mode (batch processing)	A batch in progress.	Stops the batch process. (Shutoff valve operation signal: stops; LCD OUT goes out.)
	Batch setpoint (not operating) or cumulative total count is displayed.	Batch setpoint displayed (6-digit) + RUN status displayed ↕ Displayed alternately (after a reset) Cumulative total count displayed (8-digit)
	Batch setpoint is displayed (not operating)	Switches to the batch setup mode (by holding the button depressed for more than 3 sec. after resetting).
	Missing flow-signal pulses detected.	Resets the missing flow-signal pulse detection alarm. (LCD ALM goes out.)
Batch setup mode		Establishes a batch setpoint and switches to show the batch setpoint.
Setup mode		Scrolls through the available parameters. Establishes parameters.

CAUTION: A switch from batch setpoint display to cumulative total count display is not acceptable unless the missing flow-signal detection alarm **ALM**, end-of-batch **END** and overshoot detection alarm **ALM** are all reset, and the current batch setpoint is reset.

 **button (white), internal button**  **functions**

Mode of Operation		Functions
RUN mode (batch processing)	Batch setpoint is displayed (not operating).	Resets the batch setpoint (count), Resets the end of a batch process. (LCD END : goes out.)
	An overshoot is detected.	Resets the missing flow-signal pulse detection alarm. (LCD ALM goes out.)
Batch setup mode		Moves the digit to be configured.
Setup mode		Moves the digit to be configured.

CAUTION: On resetting a batch setpoint, the LCD display will show "0" in the add counter, and Batch setpoint in the subtract counter.

 **button (green), internal button**  **functions**

Mode of Operation		Functions
RUN mode (batch processing)	Batch setpoint is displayed (not operating).	Starts a batch process. (Shutoff valve operation signal produced. LCD OUT : lights up.)
	A batch is in progress.	Batch setpoint is displayed (for a duration from 5 sec. after start of a batch process until its end while the button is held depressed).
Batch setup mode		Adjusts a figure (incremental).
Setup mode		Adjusts a figure (incremental).

CAUTION: Starting up a batch process instantly produces a valve operation signal "SV Open" [LCD **OUT** (bottom): illuminated] whereas, in a model without the 2-step open feature, it produces a shutoff valve operation signal "MV Open" [LCD **OUT** (top): illuminated] at the same time.

6.4 Switch Functions

6.4.1 Selecting Add and Subtract Counter

SW-1 in the register internal assembly selects the add or subtract counter.

SW-1 is located at the bottom of the register internal assembly. Set switch SW1-1 to either ADD or SUB.

SW1-2 is a switch for the setup mode. See paragraph 6.4.2.

Table 6.2

Switch		Description
SW1-1	ON	SUB (subtracting) counter (standard)
	OFF	ADD (adding) counter

Fig. 6.7 shows the SUB (subtracting) counter mode (standard).

6.4.2 Selecting Setup and RUN Mode

SW-2 in the register internal assembly selects the SETUP mode and RUN mode. Set SW1-2 to either RUN or SET.

Table 6.3

Switch		Description
SW1-2	ON	SETUP mode (SET) *1
	OFF	RUN mode (RUN) *2

➡ NOTE: *1: Mode to change parameters and cumulative total count.

*2: Normally set in this mode.

Fig. 6.7 shows RUN mode.

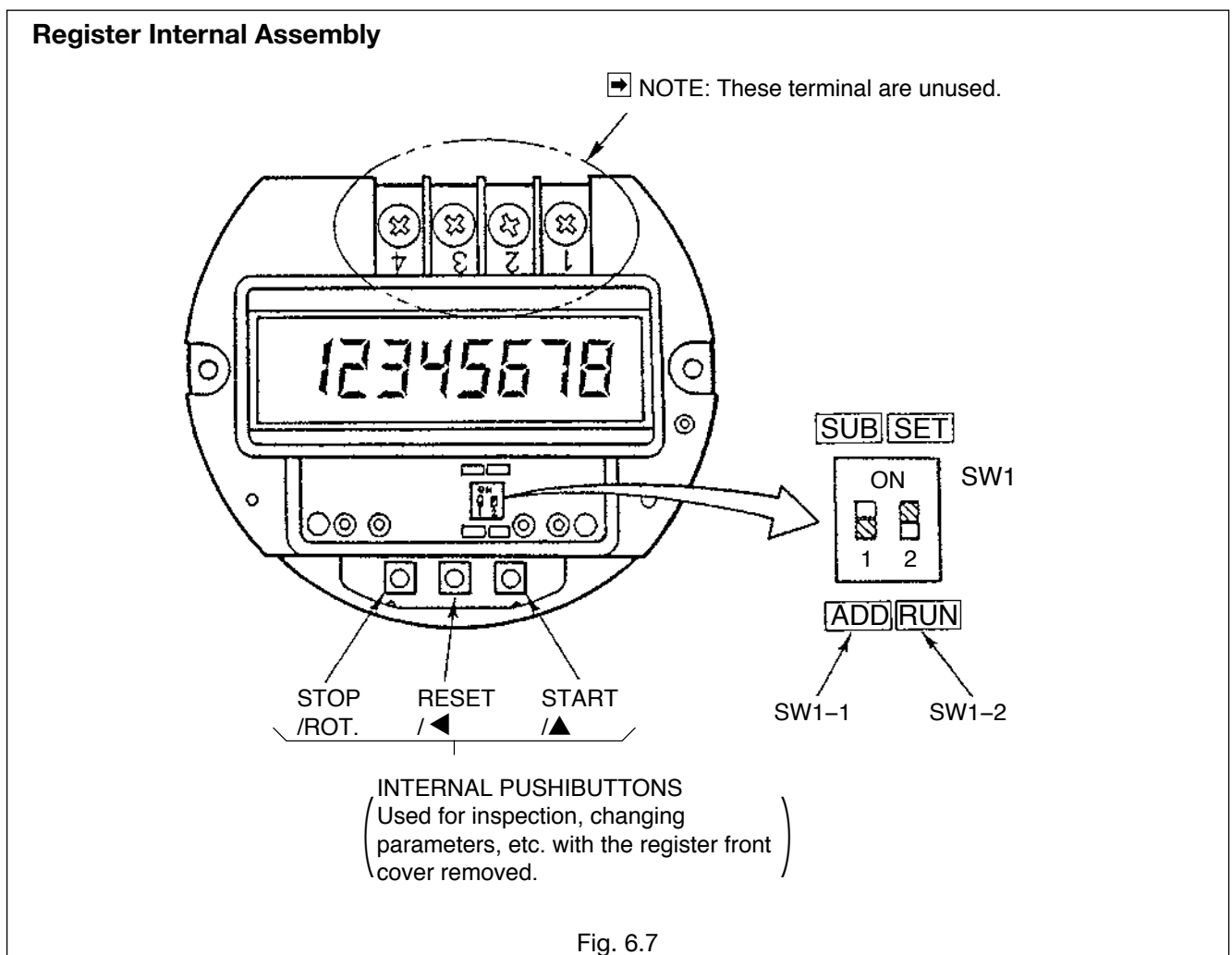

7. RECONFIGURATION

In most cases, the pushbuttons arranged on the register front cover do the job (Sec. 7.1). When the register front cover is removed for parameter changes or inspection, work with internal pushbuttons shown in Sec. 6.3 "Register Internal Assembly".

7.1 Establishing a Batch Setpoint

To establish a new batch setpoint, reset, while the LCD shows the batch setpoint, the current setpoint and hold



button depressed for more than 3 seconds. The LCD (batch setpoint) will then begin to blink, indicating

that a new setpoint is acceptable.

Conditions unacceptable for changing batch setpoints

- (1) SW1-2 is in the ON (SET).
- (2) Cumulative total count is displayed.
- (3) Missing pulses have been detected to activate an alarm.
- (4) An overshoot has been detected to activate an alarm.
- (5) A batch end output is present.
- (6) A batch process is in progress.

⚠ CAUTION:

1. If an alarm output is present, reset it before changing setpoints.
2. While the register is simply adding up counts of incoming flow signal, other than in a batch process, then changing batch setpoints presents no problem.

7.1.1 Procedure (batch setup mode)

On seeing the LCD (batch setpoint) blinking in response to the operation above, you can change the current setpoint by the following procedure.

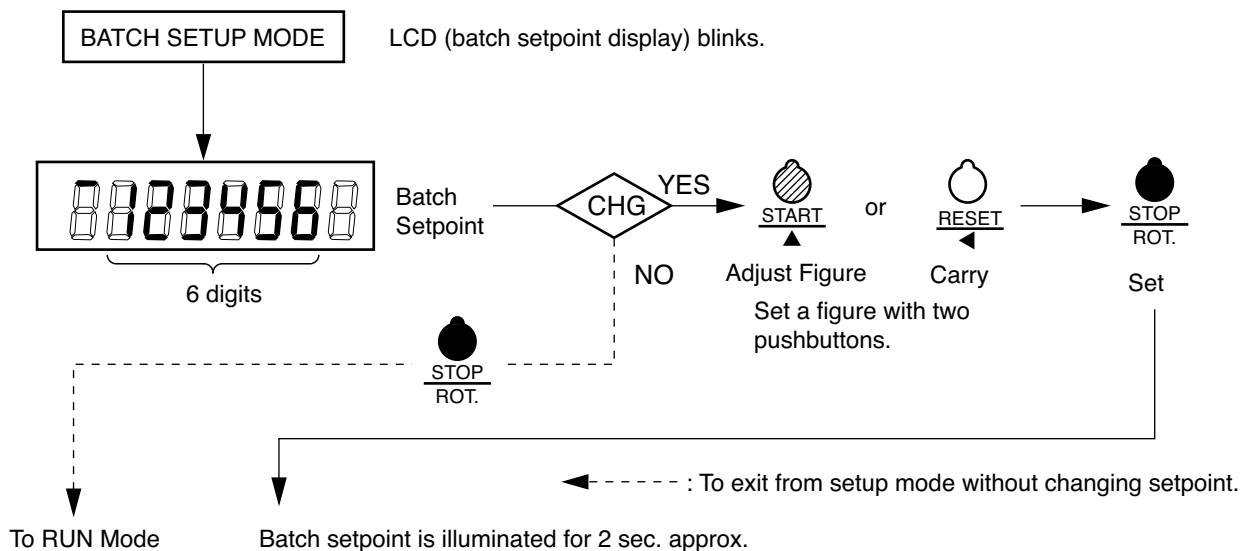

NOTE

In the add counter, following the setup procedure above, the display shows the new setpoint for 2 sec. approx. and goes back automatically to show "0" (RUN mode).

Upon depression of  button, the figure is stored and the LCD display returns to the RUN mode.

In the batch setup mode, absence of any command with button depressions for more than 10 seconds approx. causes the LCD to return to the previous setting, bringing back RUN mode automatically.

7.1.2 Example of Establishing a Batch Setpoint

● Shown below is the procedure to set up a batch at 123456 (in the add counter).

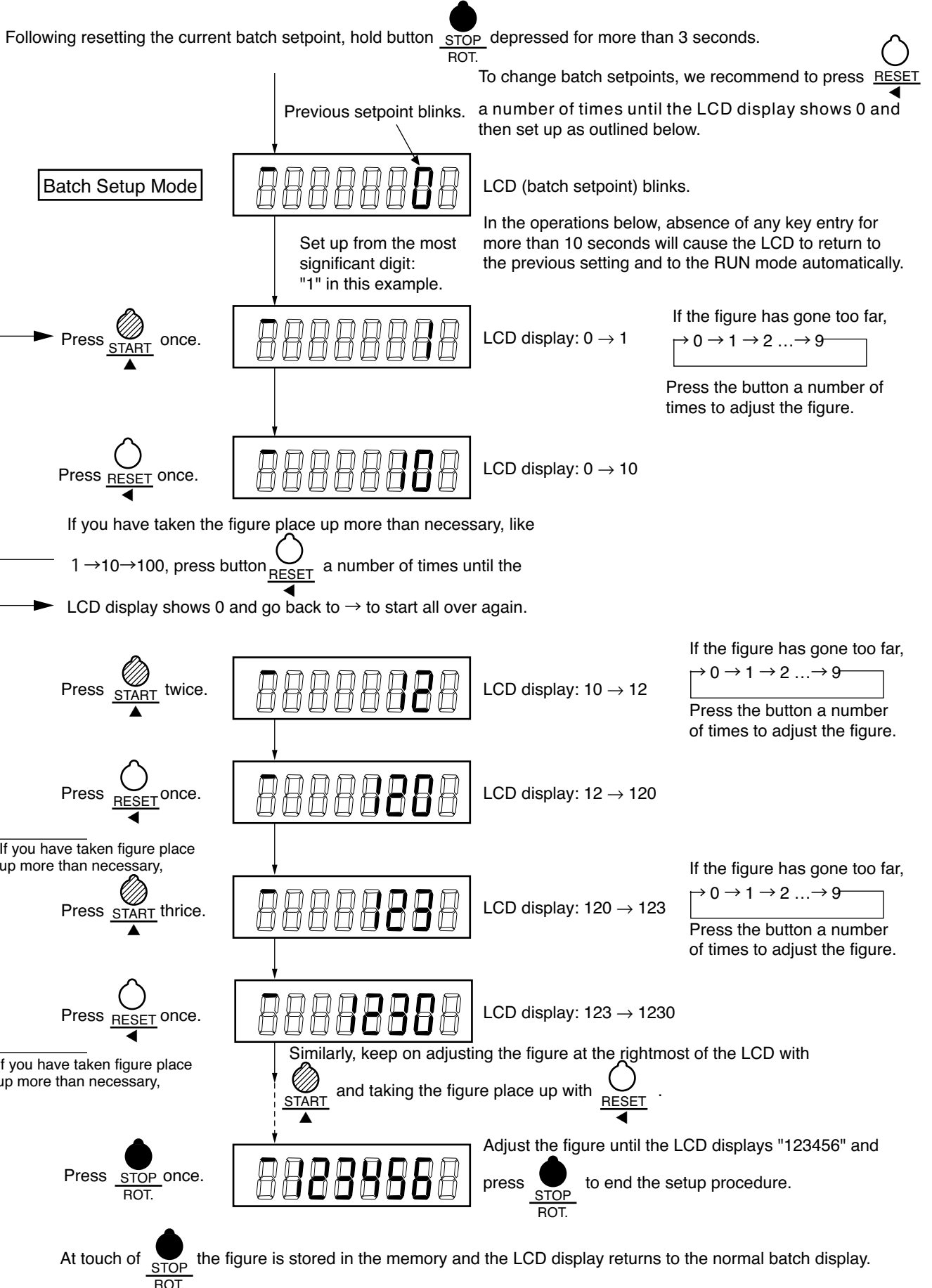

7.2 Parameter Setup (cumulative total, scaler factor, frequency division, initial and final settings, missing pulse detection, overshoot setting)

(1) Open the register front cover (see Sec. 9.2 on page 30).

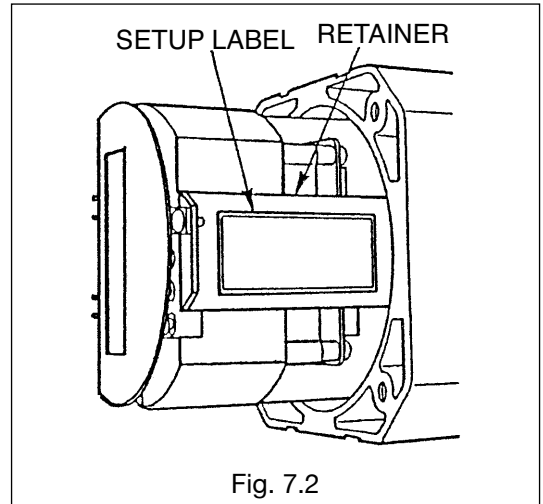
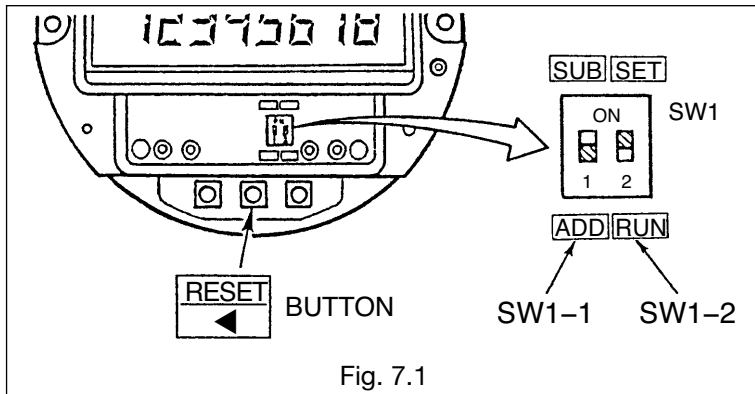

(2) Set **RUN** ⇄ **SET** switch in DIP switch SW1-2 located in the register internal assembly to **SET**.

The step taken above brings up the setup mode and the entire LCD blinks. If the LCD does not blink, press button



In this setup mode, the register can be configured to the following variables and parameters. (Default values appear on the setup label attached to the retainer inside the register.)



➡ NOTE: The register is shipped in default settings unless otherwise specified by the customer.

Table 7.1

Symbol	Item	Setting Range	Default Setting
-	Total counter reset (figure adjustment)	00000000 to 99999999	—————
F	Scaler factor	0.0001 to 1.9999	Meter factor of the flowmeter or customer's specification
d	Frequency division	0:1/1, 1:1/10, 2:1/100	Default: 0 (1/1)
oP	Initial setting	0 to 999 counts (Set to 0: 2-step opening eliminated; SV and MV open simultaneously.)	With LW76E register: 80
cL	Final setting	0 to 999 counts (Set to 0: 2-step closure eliminated; SV and MV close simultaneously.)	With LW76E register: 80
PL	Missing pulse setting	0 to 15sec. (Set to 0: Missing pulse detection alarm eliminated)	10
oV	Overshoot setting	0 to 99 counts (Set to 0: Overshoot detection alarm eliminated)	10



7.2.1 Operation in the Setup Mode

On seeing that the entire front panel LCD is blinking (by the previously outlined steps), you can change parameters and variables as follows. The procedure to enter a figure remains the same as "An Example of Batch Setup" in the previous section. Refer to that section.

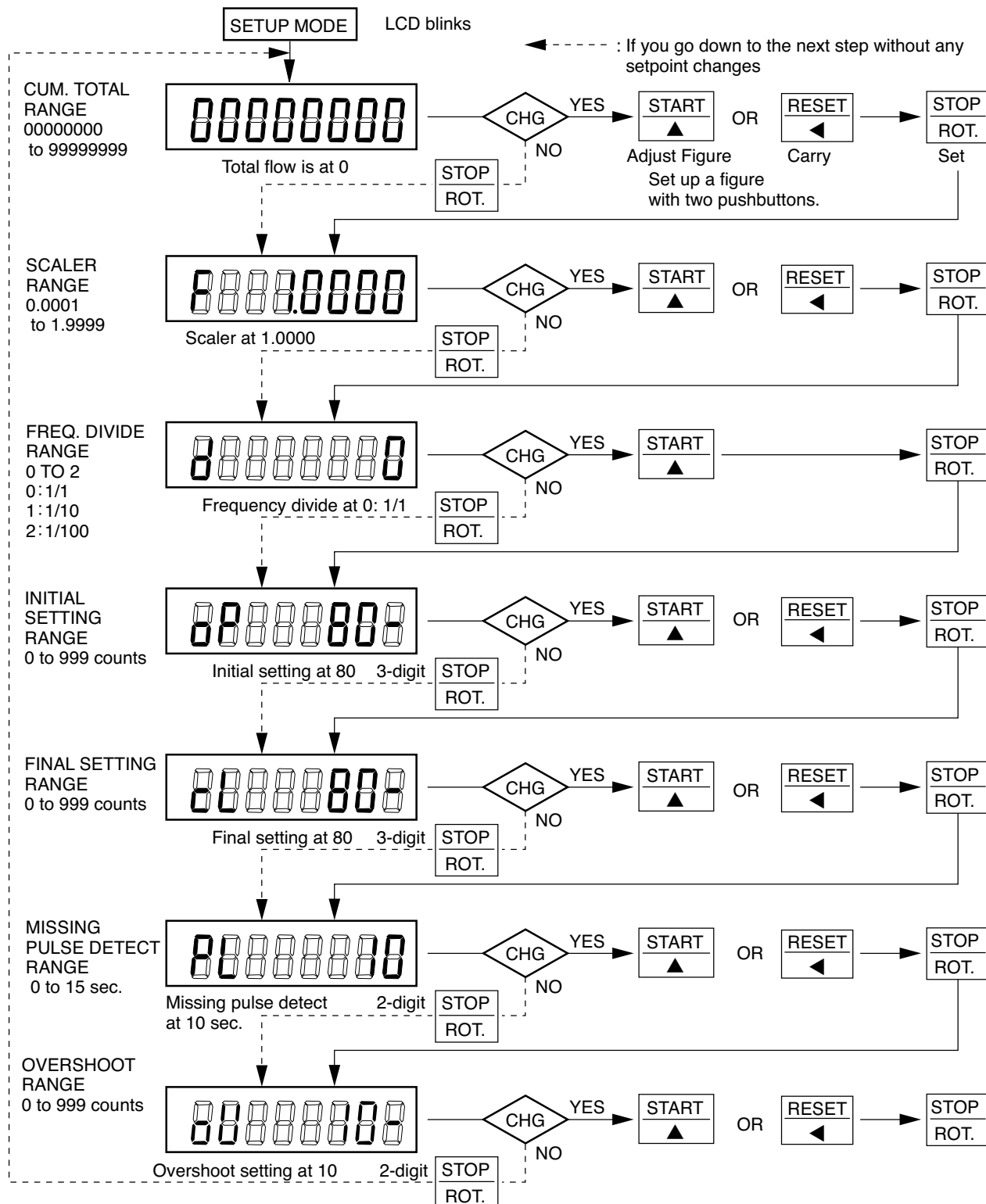
If the register front cover is removed, use internal buttons:  ,  , 



⚠ CAUTION

- After all the setup procedure has been completed, set the DIP switch SW1-2 back to .
- Any attempt to set up a figure outside the allowable setting range will fail, upon depression of  button, to change the current setting or shift to the next parameter.

8. OPERATION

8.1 Preparation Before Operation

- (1) Ensure that the flowmeter and associated equipment (shutoff valve, etc.) are correctly installed and connected to the piping assembly with no place left unfinished.

⚠ WARNING: Make doubly sure that the shutoff valve and this flowmeter are correctly connected with air tubing.

- (2) Thoroughly dehumidify supply air.
Using an air filter, or similar element, drain thoroughly to remove moisture and oil content in the supply air.
- (3) Adjust the supply air pressure to the shutoff valve to the specified air pressure with the reducing valve (air set).



Steps (3) and (4) above require daily inspection.

8.2 Preoperational Checks

⚠ CAUTION: Ensure that, without allowing the process fluid to run, the shutoff valve operates positively and that no air leaks exist at air tubing connections.

- (1) Set the quantity of a batch to any value.

➡ NOTE: See Section 7 on page 20 for setup procedure.

- (2) Show the batch setpoint in the LCD display, press  button (white), and then  button (green) to make certain that the shutoff valve opens.

- (3) Press  button (red) to confirm that the shutoff valve closes.

- (4) Repeat steps (2) and (3) above several times to make sure of correct shutoff valve opening and closing.

⚠ CAUTION: Be sure to run an operation check above with front cover in place.

8.3 Operation with Actual Flow

At first-time operation with actual process fluid, careful observation of operations sequence which is described below is required. It is essential that the flowmeter be used within the specified flow range.

(↓ Refer to the piping diagram below.)

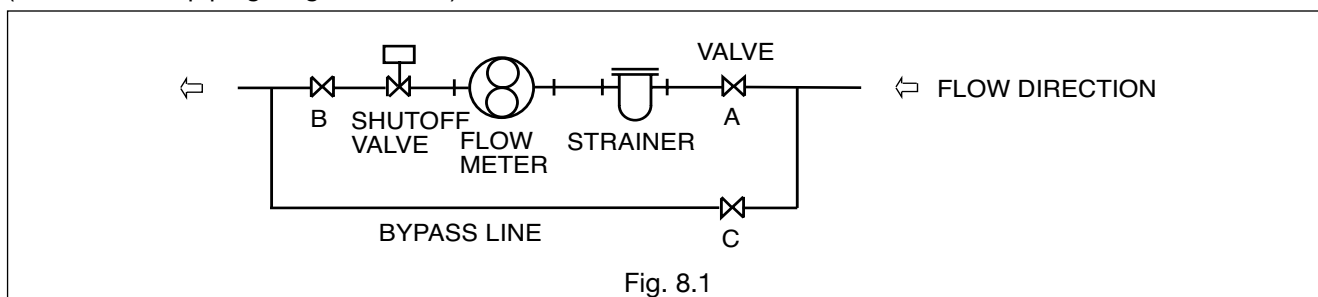

- (1) Shut off the valve (A) on the inlet side and the valve (B) on the outlet side and then open the bypass line valve (C) to allow the fluid in the bypass line, thereby removing weld chips, scale and other foreign solids left in the piping assembly.

⚠ CAUTION: This is particularly important in a newly installed piping assembly.

- (2) Open the shutoff valve manually. If it is hard to open it manually, set the missing pulse setting to "0", select any batch setpoint and press the START button.
- (3) Carefully and slightly at first, open the valve (A) upstream of the meter progressively and then, slightly at first, open the valve (B) downstream of the meter progressively.
- (4) Slowly close the bypass line valve (C) and make sure that the total counter in the register advances in response. Maintain a flowrate 10 to 20% of the maximum flowrate in this state, allow the flow to run for more than 15 minutes and make sure that air in the piping assembly has totally escaped.
In applications where temperature exceeds 60°C, run the system at least for 30 minutes in this state to ensure uniform heat distribution in the measuring chamber (preheating is necessary).
- (5) Following the break-in (preheating) period, shut off the bypass line valve (C) completely and open the upstream valve (A) progressively until fully open and slowly open the downstream valve (B) until the rated flow is reached.
- (6) Flowrate should be regulated with the valve (B) downstream of the meter and should be held within the specified rating.

8.4 Operating Precautions

- (1) When changing flowrates:
In applications where the flowrate varies or where shutoff valve opening and closure takes place in batch operation, avoid rapid changes in flowrate across the meter.
Operating the meter at flowrates in excess of the maximum allowable flowrate will nullify the guaranteed accuracy, reduce the meter life and may result in faulty conditions, such as the seizure of bearings or the rotor-to-measuring chamber contact.
- (2) Where the temperature of metered fluid changes:
Avoid rapid temperature changes in the meter. Temperature changes of the fluid in the meter should be held within 3°C per minute.
Extra care should be used particularly when making a flow measurement in batch operation without the provision of heat tracing of the piping where the fluid temperature differs from atmospheric temperature.
If rapid temperature changes are anticipated, heat trace the piping assembly as well as the meter.

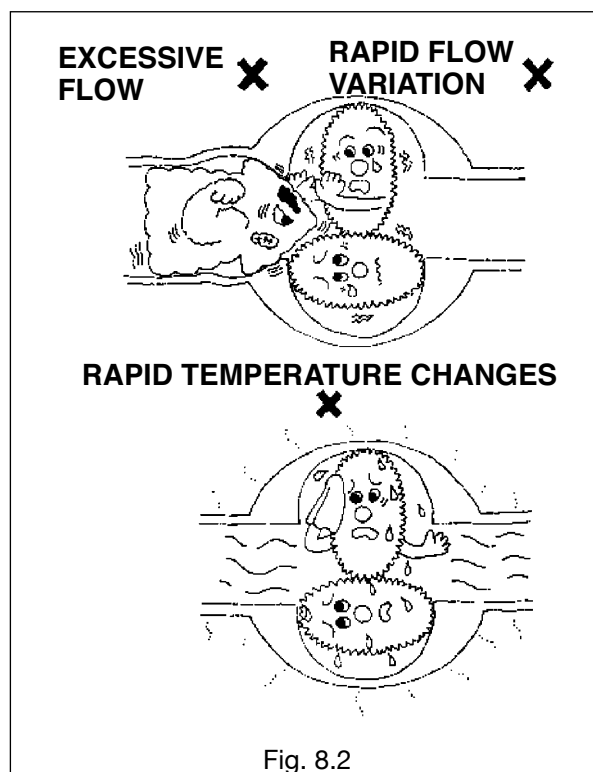

- (3) Liquids of low steam pressure
Temperature and pressure of LPG, polyvinyl chloride monomers or anything with low viscosity and low steam pressure that are prone to vaporize should strictly be controlled. During operation, the temperature of bearings in the meter is usually higher than that of the metered fluid. Vapors around the bearings can be causes of faulty conditions, including generation of unusual noise and bearing burn.
- (4) Corrosive liquids
When you make a measurement of highly corrosive liquids, such as nitric acid and sulfuric acid, appropriate materials should be used for tanks and piping assembly. Heterogeneous materials originally contained in the metered fluid or corrosive substances dissolved from tanks and pipes of inappropriate materials may lead to costly downtime, as a result of locked rotors, for example, when they are allowed into the measuring chamber.

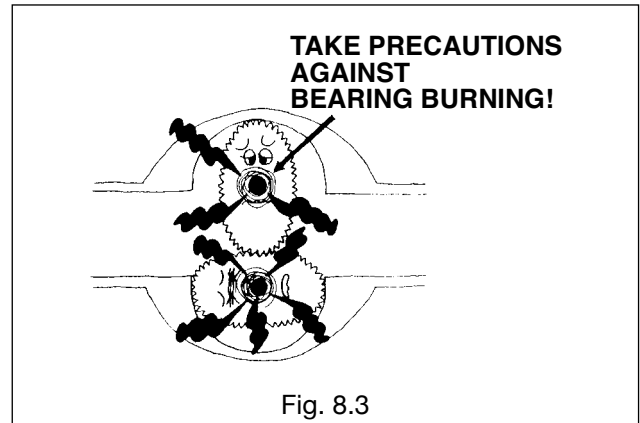

⚠ CAUTION

8.5 Precautions at Operation Shutdown

- (1) Valves should be closed progressively.
Rapid valve closure could, under certain piping conditions, cause a sharp pressure rise by water hammer, or hydraulic shock, resulting in damage to the meter.
- (2) Precautions against pressure buildup on closure
Complete closure of valves upstream and downstream of the meter makes the affected section a totally enclosed chamber and a pressure buildup inside due to the rise of atmospheric temperature could lead to an unexpected damage to the meter.
- (3) Liquids ready to adhere or gel at zero flow velocity
Liquids that tend to adhere and solidify or gel at flow velocities around zero must thoroughly be washed away from the meter interior with running cleaning fluid before shutdown. Negligence of this instruction may leave the meter as an immovable unit when the operator attempts to resume meter operation the next time.

8.6 Strainer Inspection

The strainer net should be inspected for condition and cleaned on a regular basis.

In a newly installed piping system, in particular, inspect daily first and, according to the degree of clogging of the net observed, the time interval for inspection may be reduced progressively to, say, once a week.

8.7 Starting a Batch Process

8.7.1 Preoperational Checks Before a Batch Process

When you are through with all the preparations described in the previous sections, perform the following checks:

- (1) Parameters, batch setpoint, adding or subtracting counter mode are correctly established (see Sec. 7 or Sec. 6.3)
- (2) DIP switch SW1-2 is in the **RUN** mode (see Sec. 6.3).
- (3) Register front cover is properly installed on the register body.

⚠ CAUTION: Unless the register front cover is installed in place, the pushbuttons in the front may not function properly.

8.7.2 Starting a Batch (procedure)

Behavior of the LW76E register equipped meter is described below, using a setup operation for the target batch setpoint and parameters shown in the box on the right as an example.

Example of batch setpoint and parameter setup

- Batch setpoint: 1000 counts
- Initial setting: 80 counts
- Final setting: 80 counts
- Overshoot setting: 10 counts

————▶: Normal operation

- - - - -▶: In an emergency or in trouble

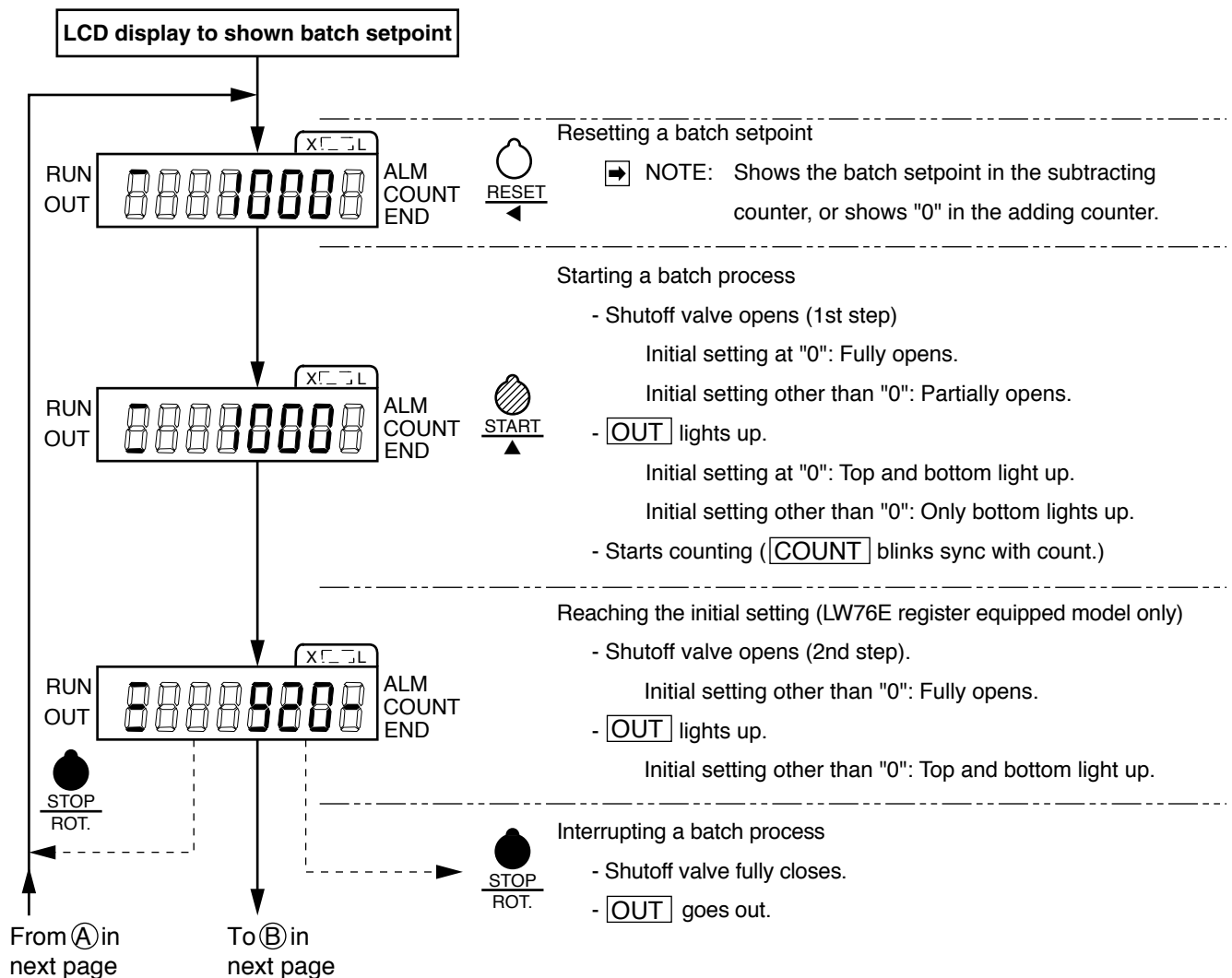

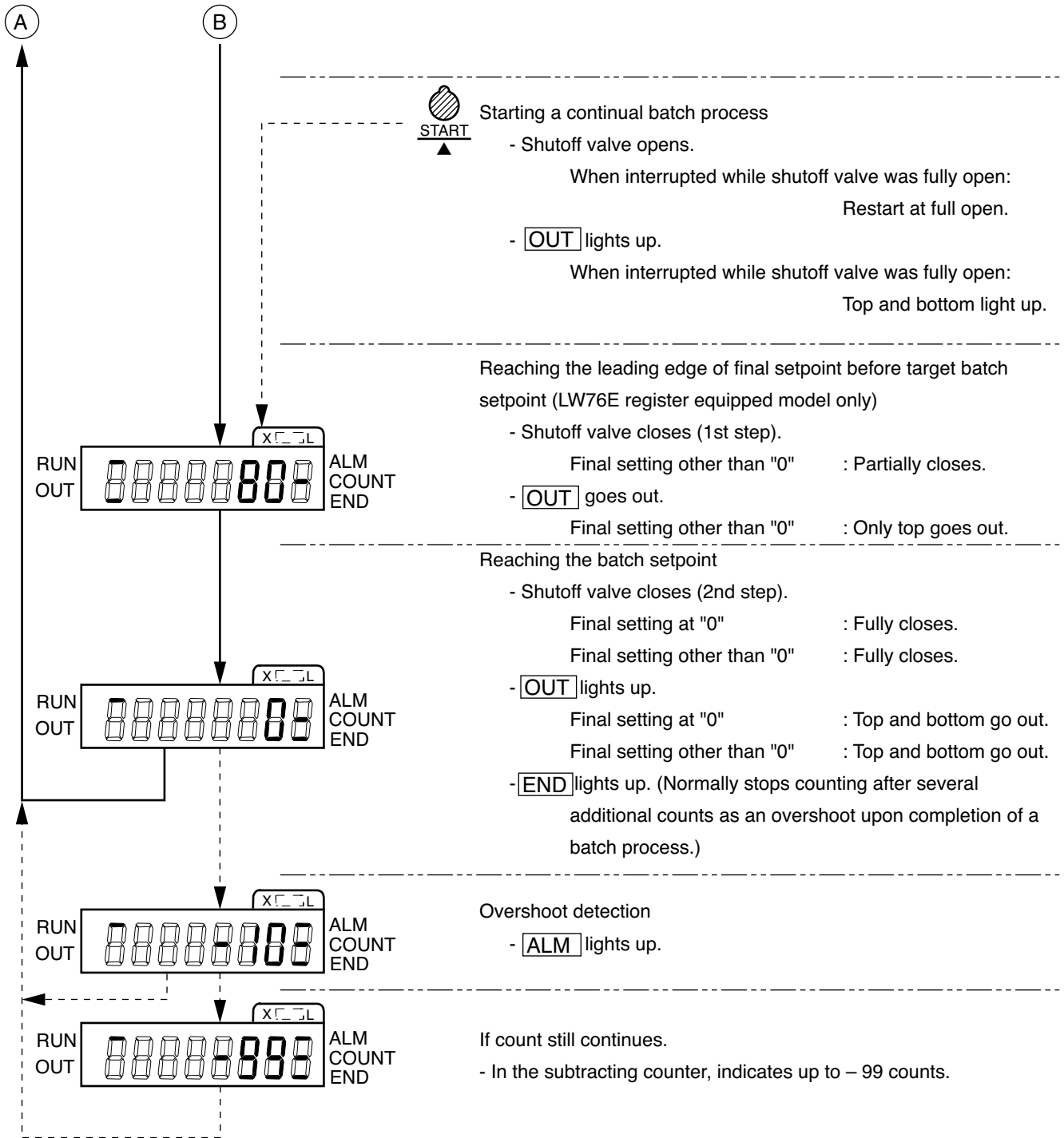

- ➡ NOTE: (1) Reaching the batch setpoint means, in the subtracting counter, the moment the total reading has reached 0 or, in the adding counter, the total reading has reached the target batch setpoint.
- (2) Batch counter display (6-digits) shows, in a subtracting counter, a negative figure below 0, continues counting down to -99 counts and stops counting. Above 999999 counts in the adding counter, it returns to 0 and continues counting.
- (3) Cumulative total counter (8-digits) keeps adding up counts, whether adding or subtracting, returns to 00000000 beyond 99999999 and continues counting.

9. INSPECTION

9.1 Register Inspection

● Test pin functions

(Show waveshapes while the fluid flows)

➡ NOTE: The register housing serves as 0V (common).

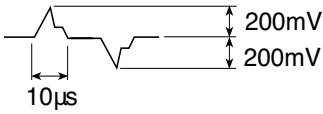
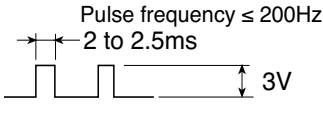
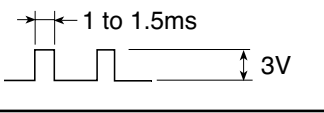
PIN NAME	FUNCTION	WAVEFORM
SIG	An amorphous sensor output waveform appears.	
IN	Accepts a simulated pulse train from the pulse checker (OVAL Model PC2201, for example). Used for making a loop check or other servicing. Input mode is Model PC2201's PG30 mode. Also accepts pulses with levels "0": 1V max. and "1": 3 to 12V, or open collector.	
PLS	A rectangular waveform after waveshaping the SIG pulse waveform. Output timing remains the same as that of SIG.	
OUT	Produces a factored pulse output with the same timing as that of the indicated count.	

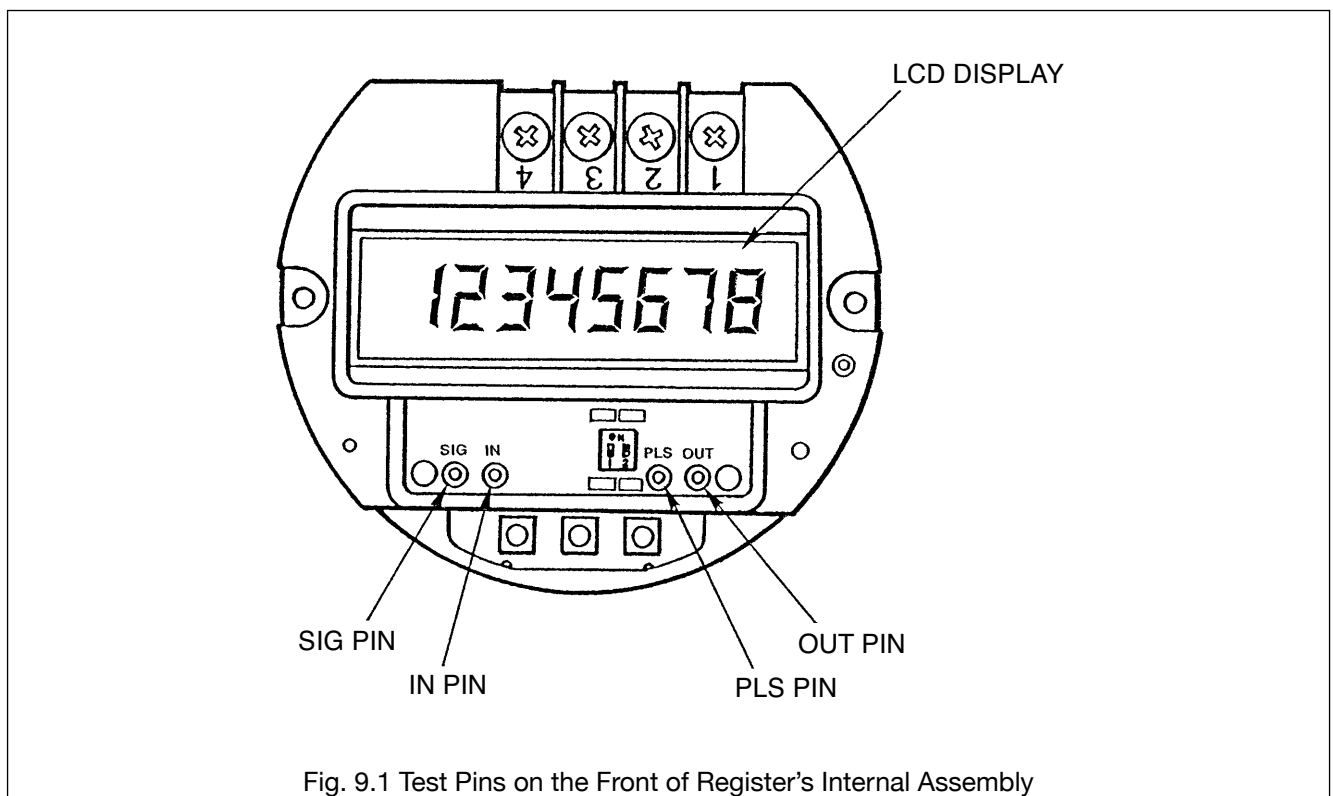

Fig. 9.1 Test Pins on the Front of Register's Internal Assembly

9.2 Register Disassembly

When you inspect or replace subassemblies, follow the procedure given below.

- ➡ NOTE: 1. Size 29 single-case construction meter is shown here. The same procedure applies to other sizes.
 2. Removing only the internal assembly, battery pack, solenoid valve unit, or sensor unit does not require steps (1) and (2).

⚠ CAUTION: Stop supply air to the shutoff valve and disconnect air signal lines beforehand.

- (1) Take off four hex socket head bolts on register sides, using hex wrench key.

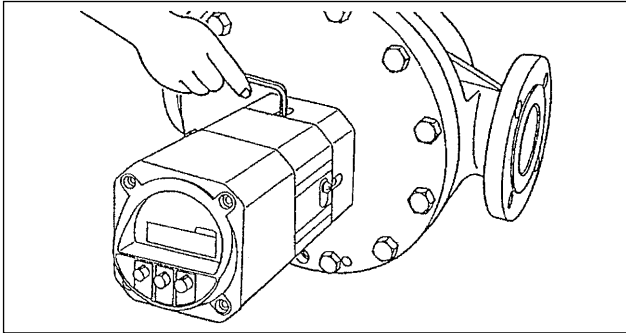

- (2) Carefully draw the register assembly out. Do so in a straight line, exercising care not to bump the sensor unit.

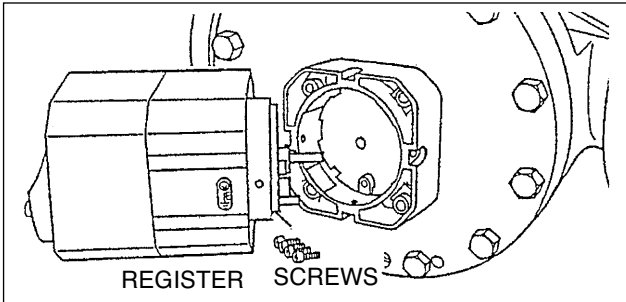

- (3) Take off four hex socket head bolts (M8) on the front of register, using hex wrench key.

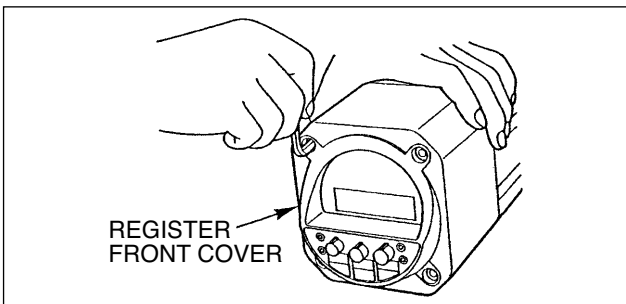

- (4) Separate the register front cover from the register body in a straight line carefully. (Use care not to bump the front cover against the internal assembly.)

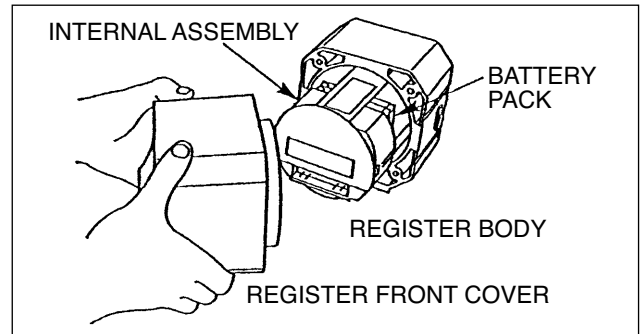

- (5) Take off two screws (M4) securing the internal assembly, using screwdriver.

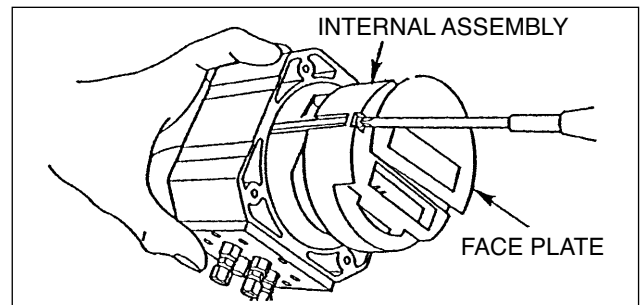

- (6) Loosen #4 terminal screw and retainer screw of the internal assembly with screwdriver and slide the hold-down strip upward with screwdriver. To prevent the hold-down strip from missing, turn it 90 deg. and install to the retainer again.

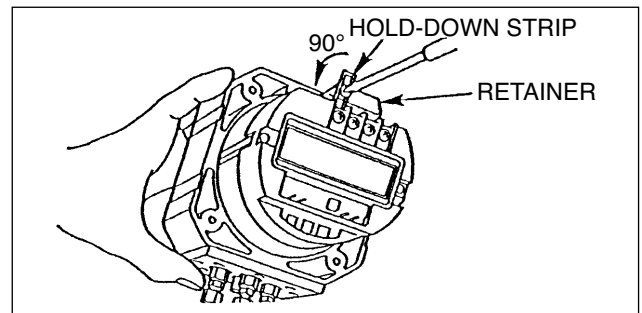

⇒ Continued on next page.

- (7) Pull the internal assembly a little forward and remove connectors CN1, CN2-1 (SV), and CN2-2 (MV) at the bottom of the battery pack.

⚠ CAUTION: With LW74E register, CN2-2 (MV) is unused. At reassembly, be careful not to make a mistake in connections.

⚠ CAUTION: Do not pull the sensor bracket forcibly, or its lead wires may break.

Now the internal assembly is ready for removal.

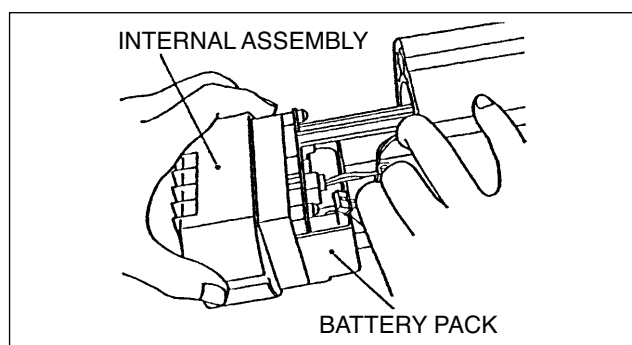

- (8) Remove the two posts securing the hold-down strip with socket wrench. Then remove three couplings at air connections and silencer from their bushings.

⚠ CAUTION: Do not take a firm grip of the silencer overmuch or it will be crushed.

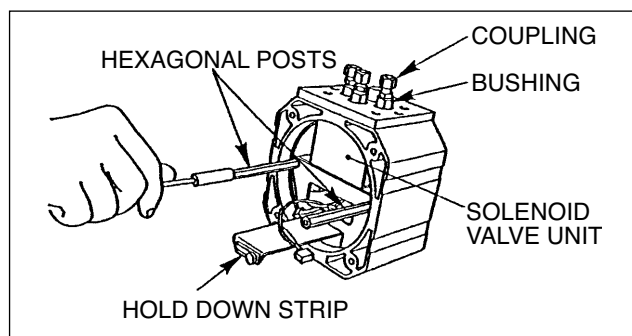

- (9) Take off eight hex socket head bolts (M4) holding the retainer, using hex wrench key.

⚠ CAUTION: At installation, tighten bolts in an alternating order to ensure even tightening.

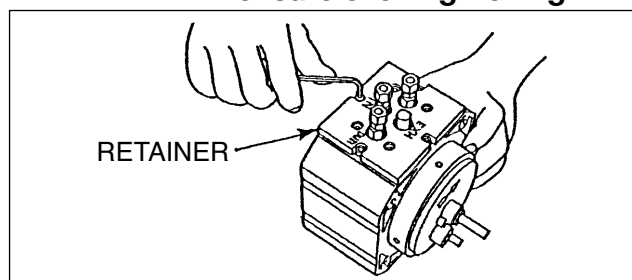

- (10) Draw the solenoid valve unit out of the register body.

Now the solenoid valve is ready to be removed.

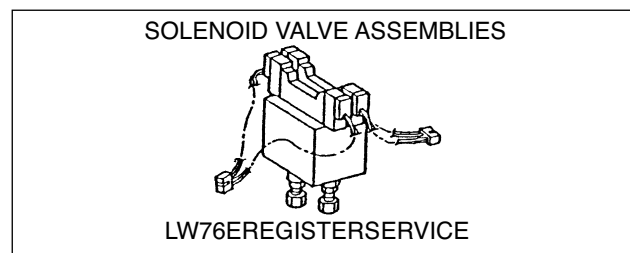

- (11) Loosen sensor retainer fitting screws (M4) with screwdriver, remove the sensor retainer and draw out the sensor unit.

The sensor unit is now ready to be removed.

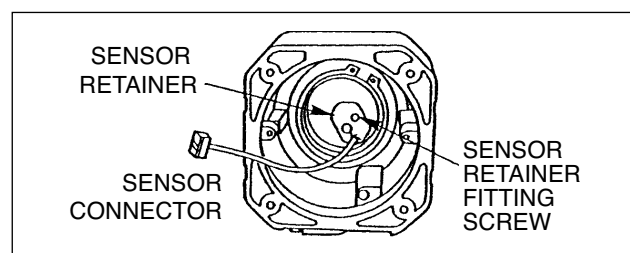

- (12) Insert a new sensor unit into the opening through which the old sensor was removed. Assembly is simply the reverse of the removal procedure. Upon completion of assembly, perform an operation check before service operation.

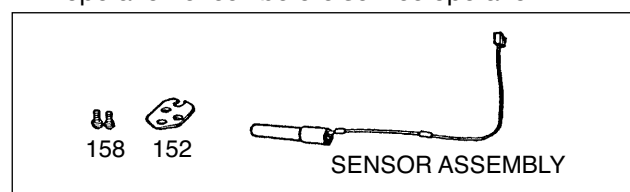

Location of Holes for Installing the Sensor

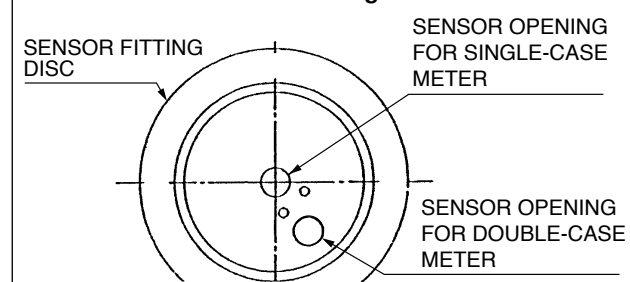

- (13) At register installation on the body, ensure that the flow direction arrow on the body agrees with the arrow mark on the sensor bracket.

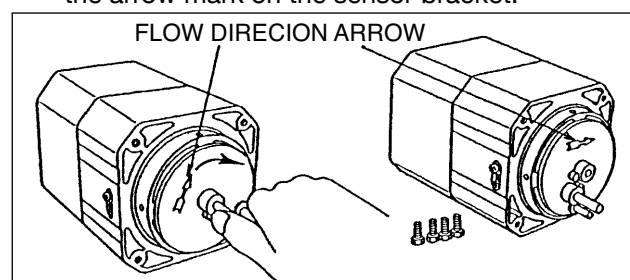

9.3 Meter Body Disassembly and Inspection

- ⦿ Although it depend on individual operating conditions, periodic disassembly and inspection should be performed at least once a year.

⚠ CAUTION: Because the Oval flowmeter is a precision industrial instrument, disassembly and inspection should be performed indoors as a rule. If it is desired to disassemble and inspect it as installed in the field, an important precaution to remember is to reduce the internal pressure of the piping assembly to a safe level, shut off valves upstream and downstream of the meter completely, drain the piping assembly and then place a suitable fluid receptacle directly below the flowmeter. Exercise care to keep each component disassembled free from grit and dust.

- Meter Inspection

When the fluid does not flow through the meter, the oval rotors might be stuck with scales, resulting in stop of their rotation.

9.3.1 Single-case Construction Meter Body Disassembly and Inspection

➡ NOTE: Size 29 single-case construction meter body is shown here. The same procedure applies to other size meters.

- (1) Take off all the twelve hex bolts (105), using wrench.

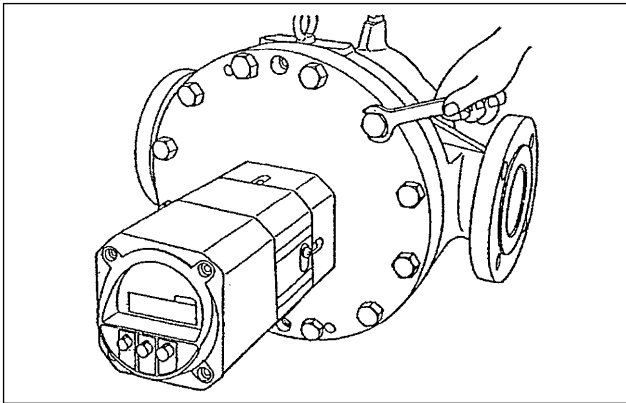

- (2) With the front cover removed, the measuring chamber with oval rotors and other components are accessible.

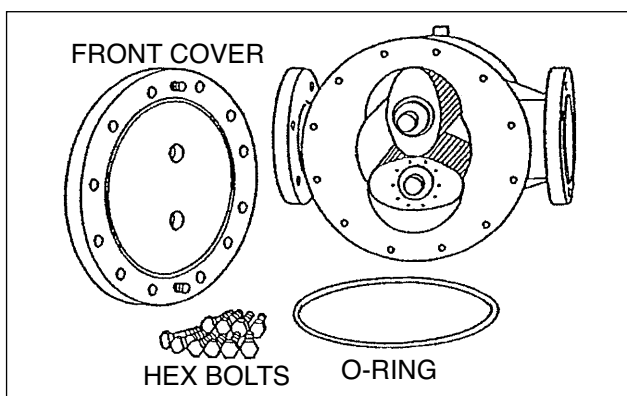

- (3) Remove oval rotors from the measuring chamber and inspect them for condition. (Rotor shafts should be drawn out straight forward.)

- (a) Inspect the oval rotors to see if they are stuck with foreign solids.
- (b) Check the rotors, shafts and other components for wear.
- (c) Inspect the measuring chamber and the inner wall of front cover for damage or any other sign of unusual condition.

Upon completion of these inspections, clean the oval rotors, rotor shafts, measuring chamber and front cover with clean water or suitable solvent thoroughly.

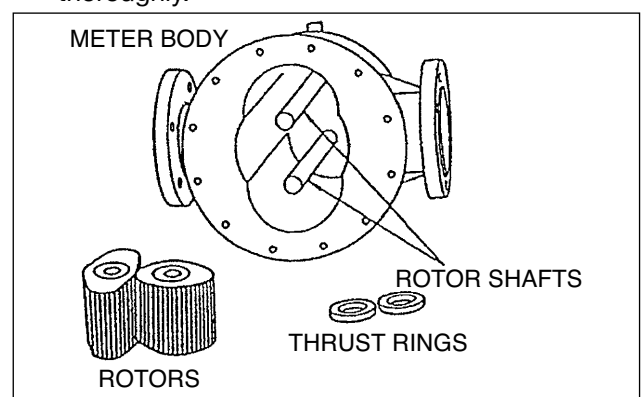

⚠ CAUTION:

1. Deep scratches, high spots due to impressions, or other flaws should be reconditioned flat with oil stone or other tool.
2. If the areas which have been forcibly in contact with front cover jacking bolts are distorted outwardly, recondition it flat with oil stone.
3. Excessive reconditioning may result in a loss of meter accuracy.

9.3.2 Single-case Construction Meter Body Assembly Procedure

◆SERVICE NOTE BEFORE ASSEMBLY◆

⚠ Oval rotors, inner walls of the rotor shafts, inner wall of the measuring chamber, inlet and outlet ports, and inner surface of the front cover should be thoroughly washed clean, completely removing dust.

(1) Rotor Installation

Rotor installation is correct if the side where signal generating magnets are embedded faces the register (top of the measuring chamber) and the side with match marks (•) (••) faces the front cover.

Carefully install the rotors with the 1st rotor (match mark "•") on the shaft with "1" stamped on the outside of measuring chamber and the 2nd rotor (match mark "••") on the shaft with "2" stamped.

Ensure that the match marks are as shown in the inset.

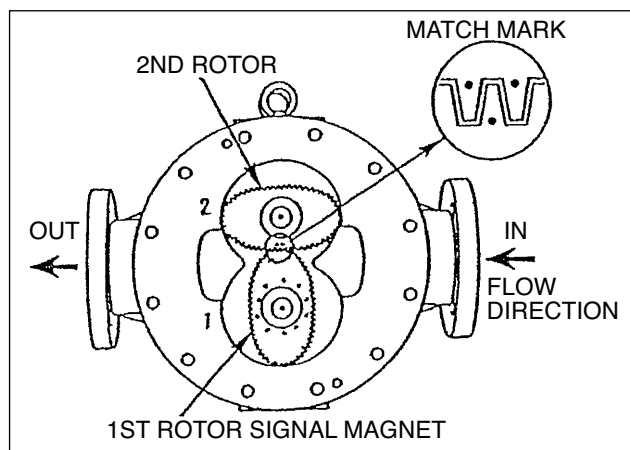

(2) Make sure of the smooth rotation and correct engagement of the rotors by rotating them with hand.

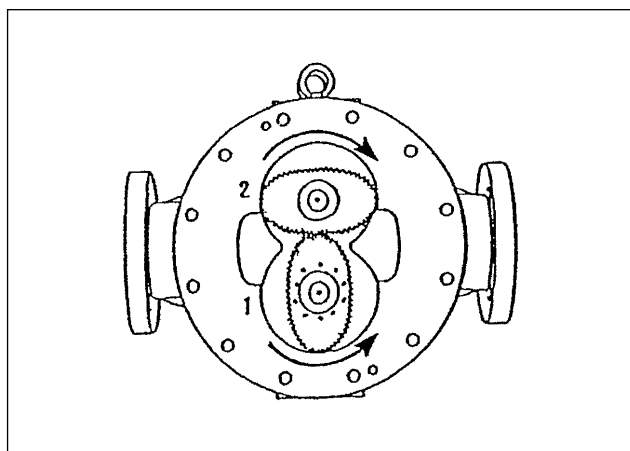

(3) Front Cover Installation

Firstly install O-Ring (103) on the front cover. If the O-Ring is damaged or swollen with metered liquid, it will not fit in the groove. If such is the case, replace with a new one.

Align the locating pins of front cover with its pin slots in the meter body and, fitting the rotor shafts into rotor shaft sockets in the front cover, force the meter body until the locating pins fit firmly into the pin slots in the meter body without slanting the front cover. Install 12 hex bolts (M16) and tighten them evenly until the front cover is closely in contact with the meter body.

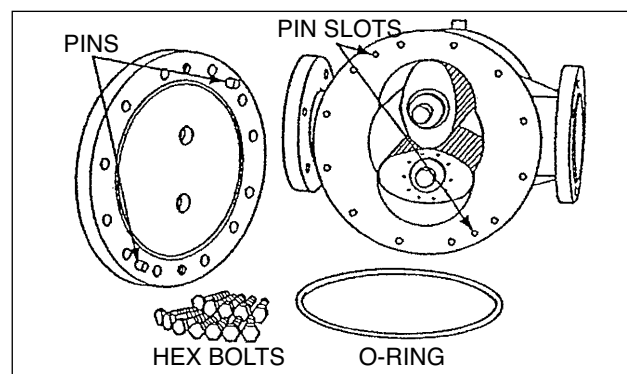

(4) Confirming Smooth Rotation

With air or water, make sure to see that the rotors move freely.

⚠ CAUTION
Rotation check should be performed at low rotor r.p.m.
Violent rotor spinning may cause a damage to the components, and bearing burn.

⚠ CAUTION:
This meter is not compatible with any other registers. Never attempt to replace it.

9.3.3 Double-case Construction Meter Body Disassembly and Inspection

➡ NOTE: Sizes 28 and 29 double-case construction meter body is shown here. The same procedure applies to other size meters.

(1) Using hex key, take off four bolts (115). Holding the register assembly in both hands, carefully separate it from the meter body.

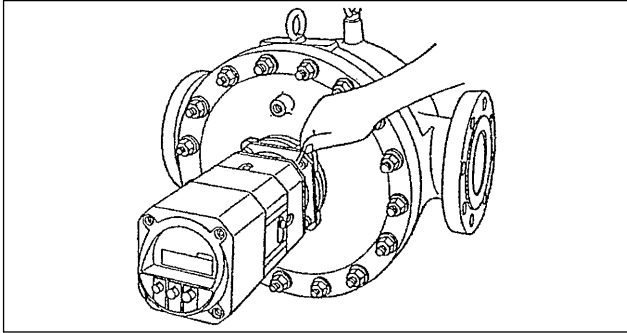

(2) Using hex key, take off eight bolts (125) and remove sealing flange (124)

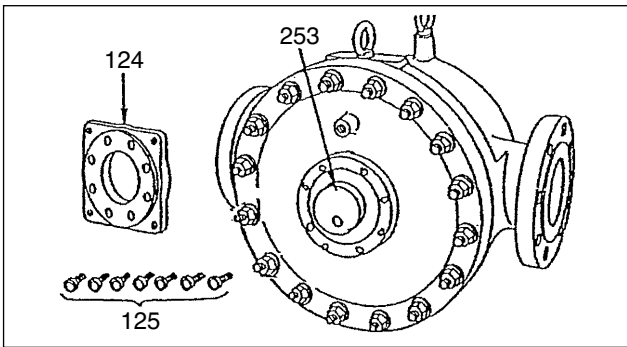

(3) Using stop ring pliers, remove stop ring (254). At assembly, install part (253) and then tighten front cover (102).

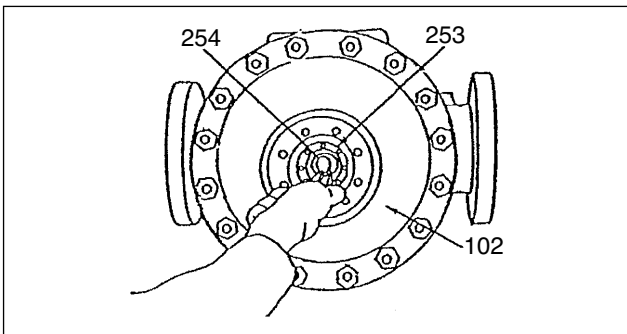

(4) Remove the signal generating magnet assembly. Take off 16 stud bolt nuts (119) and the front cover is ready to be separated.

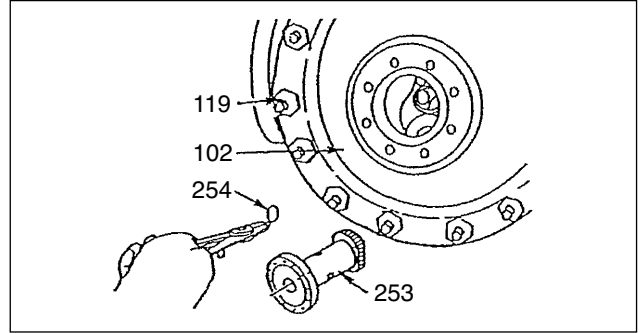

(5) Take off four hex bolts (218) and use two of them in the threaded jack screw holes in the major shaft holder (204) to jack the major shaft holder by tightening them alternately as shown.

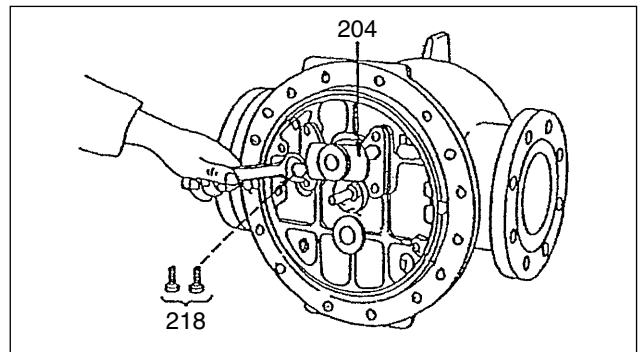

(6) Using stop ring pliers, remove stop ring (216) and remove uniform-motion drive gear (214). At assembly, install in line with the locating pins of uniform-motion gears.

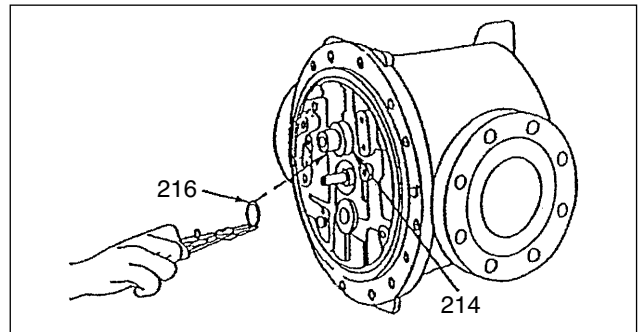

- (7) Using hex key, take off six bolts (217) and use two of them in the threaded jack screw holes in the inner case top cover (202) to jack the inner case top cover by tightening them alternately.

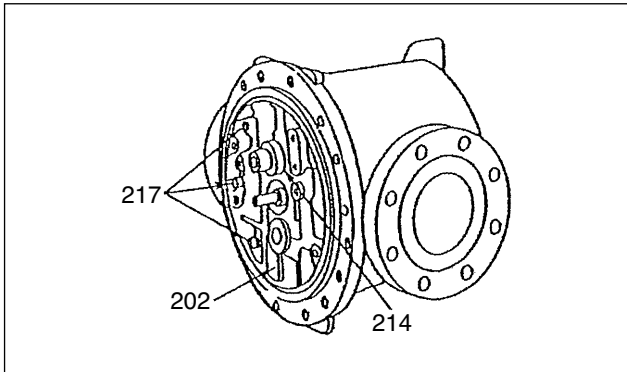

- (8) Now the measuring chamber is ready for inspection.

Wash clean the oval rotors, measuring chamber, and inner case top cover with suitable cleaning oil. Reassemble them exercising care to keep grit and dust from entering.

At assembly, align match marks as shown and make sure of smooth rotor rotation.

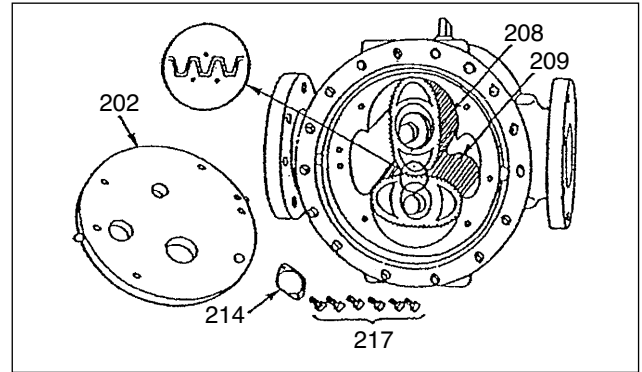

9.3.4 Double-case Construction Meter Body Assembly Procedure

Assembly is the reverse of the removal procedure, but observe the following instructions.

Illustrated at right is the way the uniform-motion gears are assembled.

At assembly, careful attention must be paid to the proper engagement of uniform-motion gears. In line with match marks, slide the arrow marks as shown. Following gear engagement, be sure to make one complete revolution to ensure smooth rotation.

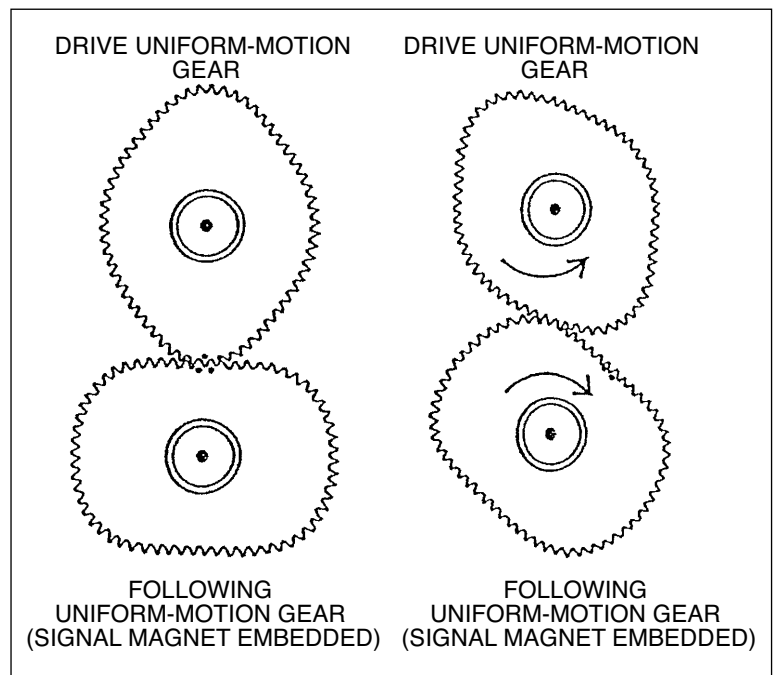

⚠ CAUTION: This meter is NOT Compatible with any other registers. Never attempt to replace it.

10. ABOUT THE BATTERY PACK

The register operates on a built-in battery. Take the following precautions.

⚠ CAUTION

1. **The battery pack is of dedicated one. Do not attempt to use commercially available batteries of other type.**
2. **The battery pack is of one-piece molding. Never give impact shock or disassemble. Or loss of performance may possibly result.**
3. **For storage, keep moisture and dust out.**

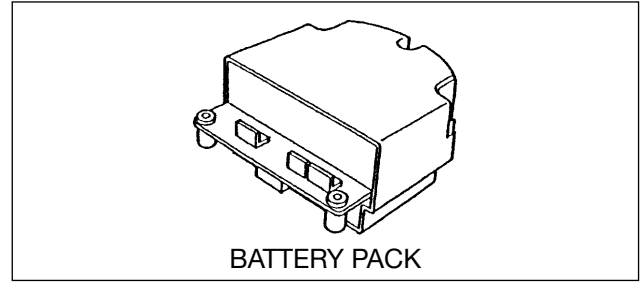

Battery packs are available at your nearest OVAL sales representative or at OVAL Service Center.

10.1 Battery Life

This battery is good for about 4 years.

The life expectancy is based on an 8-hours-a-day operation basis but may vary with operating and environmental conditions.

When the battery is beginning to run down, an alarm "BATT" blinks in the display. As this state advances, a warning "ALM" comes on, closing the shutoff valve automatically if a batch process is in progress (shutoff valve is open) and saving variables of the total count and cumulative total in the memory.

As a rule of thumb, it takes about 8 days from "BATT" to begin blinking until "ALM" to come on. Good practice is to replace the battery in this period.

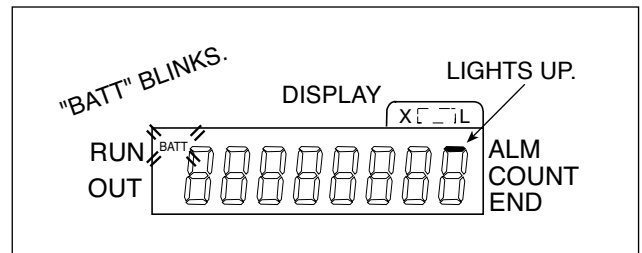

10.2 Battery Pack Replacement

Battery pack replacement procedure is given below.

➡ **NOTE:** For safety's sake, do not fail to make sure that the shutoff valve remains closed before you start working. If it is in the open position (metering), close the shutoff valve to prevent erratic operation following the replacement.

- (1) Take steps (3) through (7) of Sec. 9.2 "Register Disassembly".
- (2) Take off 5 screws securing the battery pack in place.

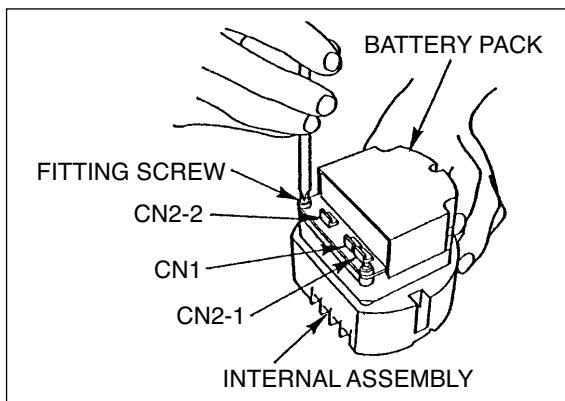

- (3) Pull the battery pack out of the internal assembly (the battery pack is coupled to the internal assembly with connectors).

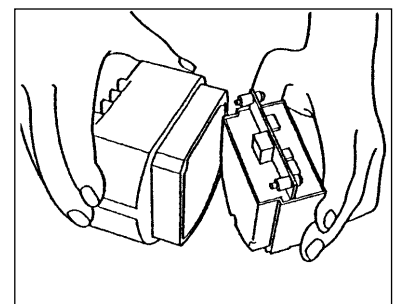











- (4) Install a new battery pack in reverse order of removal.

⚠ CAUTION:







Use care to avoid a distorted or out-of-position connector while installing the battery pack in the internal assembly.

11. TROUBLESHOOTING



➡ NOTE: If troubleshooting below does not work at all, seek our service.

SYMPTOM	POSSIBLE CAUSE	CHECKOUT AND COUNTERMEASURE	Ref. page
1. Display is dead.	Battery pack is not in place.	Remove register front cover to see if the battery pack is in place.	30 36
	A weak battery.	Check voltage across test pin IN on the display board of internal assembly and terminal G of the housing. (1) Correct level: 2.6V or higher (2) Low level: 2.5V or lower (1) indicates a fault suspected in the internal assembly. (2) requires battery pack replacement.	29
2. Cannot establish a batch setpoint.	Not switched in the batch setup mode. (LCD display does not blink showing the setup mode.)	Press  RESET button once and then hold the  STOP ROT. button depressed for more than 3 sec. If pressing  RESET button followed by  STOP ROT. button depression fails to switch to the setup mode, repeat the same procedure with internal buttons on the internal assembly. If this proves to be successful, a fault is suspected in the external buttons or in the internal assembly.	20
	A desired batch setpoint is shown, but the  STOP ROT. button has not been pressed to set it.	Following your choice of setpoint, don't forget to press  STOP ROT. button to set it. (A pause for next operation longer than 10 sec. in the course of setting will result in returning to the previous setting automatically.)	20
	Can set a batch setpoint but, upon  STOP ROT. button depression, the display reading return to "0".	If in the ADD mode, the display, following a batch setting, shows it for 2 sec. approx. and then "0" in the standby mode.	20
	Can not set a desired batch set point.	If adjusting a figure or carrying a number to the next column with external buttons is disabled, repeat the same procedure with internal buttons on the internal assembly. If this proves to be successful, a fault is suspected in the external buttons or in the internal assembly.	20
3. Cannot set parameters.	Not switched in the setup mode.	Open up the register front cover and make sure that SET ⇄ RUN of SW1-2 in the internal assembly is in SET and press  RESET button once.	22
	Cannot set up parameters.	Failure to set up parameters with internal buttons indicates a fault suspected in the internal assembly.	22 23
4. Shutoff valve fails to respond to  START button depression.	 START button is not pressed in as far as it will go.	If pressing  START button as far as it will go does not work, repeat the same procedure with the internal buttons. If this proves to be successful, a fault is suspected in the external buttons or in the internal assembly.	16

⇒Continued on next page.

SYMPTOM	POSSIBLE CAUSE	CHECKOUT AND COUNTERMEASURE	Ref. page
4. Shutoff valve fails to respond to  button depression.	Batch setpoint at "0".	Set to any batch setpoint other than 0.	21
	Not reset after a batch operation.	Reset each time a batch process has been completed.	21
	Shutoff valve operating air pressure is low, or not supplied.	Readjust air pressure with reducing valve, etc.	13
	Air signal line for operating the shutoff valve is connected incorrectly.	Referring to Sec. 5 "Air Signal Line Connections" in this manual, inspect air signal line connections.	13 to 15
	Trouble lies in the solenoid valve. (Air output signal from the solenoid valve fails to be switched.)	Referring to Sec. 5 "Air Signal Line Connections", make sure of proper air signal switching and its output.	13 to 15
	Trouble lies in the shutoff valve (if air output signal from the solenoid valve above has been properly switched).	Isolate problems in the shutoff valve.	-
5. Shutoff valve responds to  button but the process fluid fails to flow.	Flowrate is low.	Open shutoff valve progressively.	-
	Pump pressure or head pressure is low.	Taking pressure loss of the entire piping system into account, adjust to the proper pump or head pressure.	-
	Oval rotors stuck with solids and locked, blocking the fluid flow.	Referring to Sec. 9.3 "Flowmeter Body Disassembly", disassemble the meter and inspect it for condition.	32 to 35
6. Shutoff valve responds to  button and the process fluid flows, but the totalizer does not count.	Trouble lies in the sensor assembly.	Make sure to see if the sensor provides a flow signal output. Referring to Sec. 9.1 "Register Inspection", monitor waveshapes at test pins [SIG] and [PLS].	29
	Flowrate signal frequency has exceeded its limit.	Inspect similar to the above and make sure that the pulse frequency at test pin [PLS] is held below 200Hz.	29
	Sensor installed the wrong way.	Referring to Sec. 9.2 "Register Disassembly", inspect the sensor for correct installation.	30 31
	Oval rotors installed the wrong way.	Referring to Sec. 9.3 "Flowmeter Body Disassembly", inspect the meter for correct installation.	32 to 35
7. Pressing  button fails to stop the shutoff valve.	Double-acting type shutoff valve: Shutoff valve operating air pressure has decreased during a batch process.	Readjust air pressure with reducing valve, etc.	12 to 13
	 button is not pushed in all the way.	If pressing  button all the way does not work, repeat the same procedure with internal buttons on the internal assembly. If this proves to be successful, trouble is suspected in the external buttons or in the internal assembly.	16 19
8. Shutoff valve does not open promptly upon  button depression.	Time lag is not consistent.	Any fluctuations in shutoff valve operating air pressure?	-
	Time lag is consistent.	The compressor has adequate air capacity? Any leaks at pipeline connections?	-
9. Unusual sound from the flowmeter body.	Air is entrapped.	Reduce flowrate and let the air in the pipeline out completely.	-
	Process fluid vaporizes in the pipeline.	Reduce flowrate and adjust process fluid temperature and pressure until vaporization ceases.	-
	Oval rotors are revolving in contact with the measuring chamber.	Referring to Sec. 9.3 "Flowmeter Body Disassembly", disassemble and inspect for condition.	32 to 35

⇒Continued on next page.

SYMPTOM	POSSIBLE CAUSE	CHECKOUT AND COUNTERMEASURE	Ref. page
10. Liquid leaks from the pipeline.	Incomplete seals at pipeline connections.	Retighten bolts at pipeline connections or replace gaskets.	-
	Incomplete seal in the rear cover of flowmeter body.	Inspect flowmeter rear cover fitting bolts for tightness or replace O-ring with new one.	32 to 35
11. Counts while the shutoff valve remains closed.	Leaks from shutoff valve or pipeline connections.	Inspect shutoff valve and pipeline connections for leaks.	-
	Air pockets exist between the shutoff valve and flowmeter body; the rotors keep a rocking motion in response to pulsating pump pressure.	Discharge the air to atmosphere.	-
12. Counter reading too high.	Pulsation of the fluid causes the rotors to move in a rocking motion.	Provide a check valve and accumulator.	
	Influenced by external magnetic fields. (The flow sensor picks up external magnetic fields of a motor, generator, etc.)	Isolate from external magnetic fields.	11
13. Counter reading too low.	Air entrapped.	Discharge the air to atmosphere.	-
	Influenced by external magnetic fields (the flow sensor picks up external magnetic fields of a motor, generator, etc.)	Isolate from external magnetic fields.	11
14. "BATT" alarm blinks.	Indicates a weak battery.	Referring to Sec. 10.2 "Battery Pack Replacement", replace the battery pack early.	36
15. "BATT" alarm blinks and "ALM" stays on.	A low battery alarm. (The battery is generally no longer serviceable in this state.)	The meter is out of service until the battery is replaced. Referring to Sec. 10.2 "Battery Pack Replacement", replace with a new one.	36
16. Batch process fails to stop at the target setpoint.	Trouble lies in the internal assembly.	Does "OUT" go out and "END" light in the LCD at batch setpoint? Monitor waveshapes according to Sec. 9.1 "Register Inspection."	17 29
	Trouble lies in the solenoid valve.	Is the output (air signal) from solenoid valve switched correctly at batch setpoint? (With LW76E: OUT 1 OFF, OUT 2 OFF)	15
17. Batch process stops while metering is in progress.	Single-acting shutoff valve: Shutoff valve operating air pressure has dropped.	Has the air pressure dropped below the operating pressure range?	-
	Intermittent interruption of the process fluid flow during a batch process causes missing pulse detection and shutoff valve closure signal generation.	Make sure of process fluid flow.	10
18. Cannot reset the alarm.	 button is not pushed in as far as it will go.	If pressing the  button fails to reset, repeat the same procedure with internal buttons in the internal assembly. If this proves to be successful, trouble lies in the external buttons or in the internal assembly.	16 19
19. LCD display is dim.	The register is located higher than the operator's eye level.	You can best view this LCD from above. Adjust its installation height for best readability.	11

12. EXPLODED VIEWS AND PARTS LIST

● When you order replacement parts, specify the stock No., flowmeter model, instruction manual No., symbol No., part name and the quantity desired.

12.1 Size 29 Single Case Construction Meter Exploded View and Parts List

12.1.1 Size 29 Single Case Construction Meter Exploded View

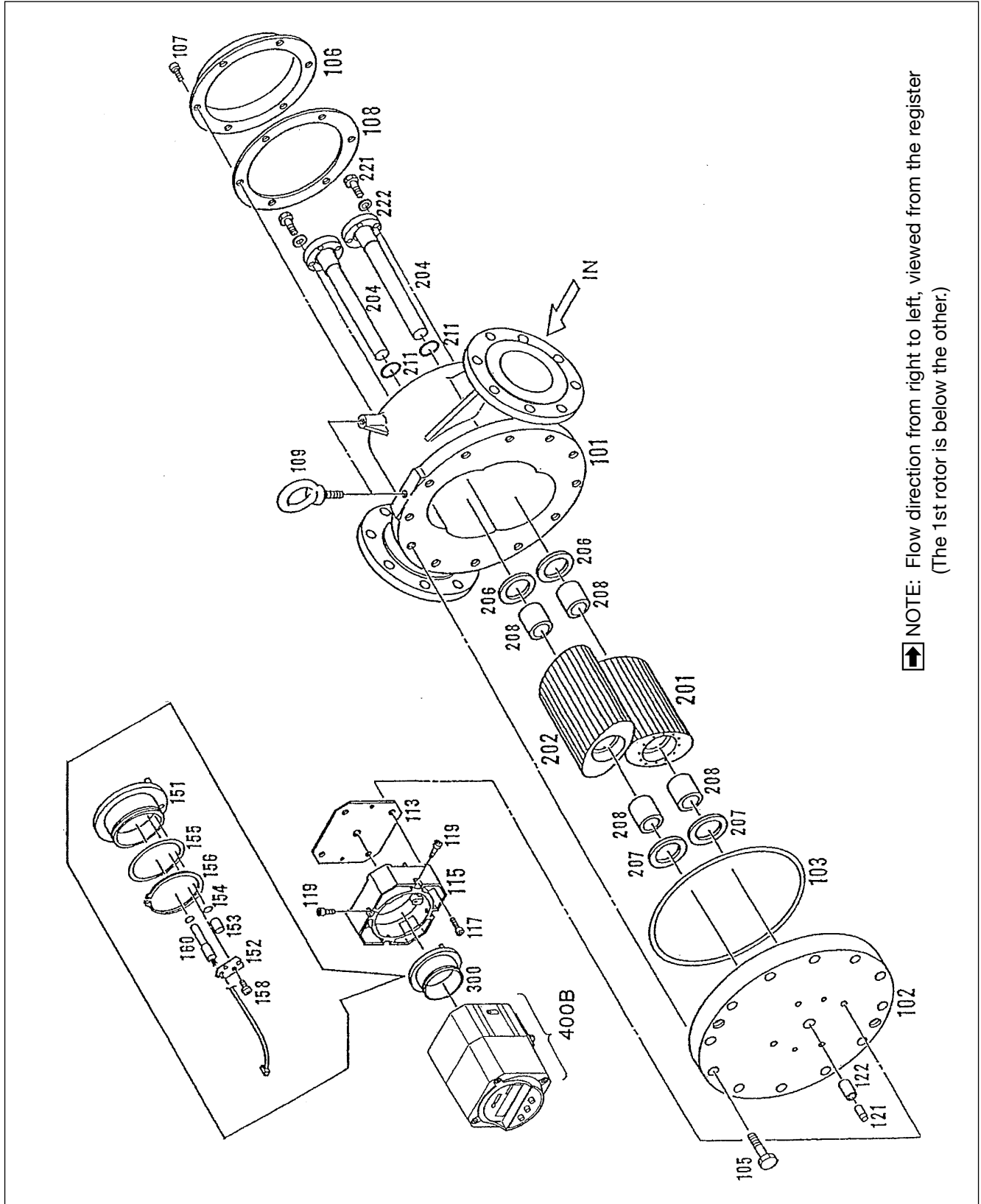

➡ NOTE: See next page for parts list.

12.1.2 Size 29 Single Case Construction Meter Parts List

Symbol No.	Part Name	Q'ty	Remarks
100	Meter Body Assembly	1 set	
101	Meter Body	1	
102	Front Cover	1	
▲103	O-Ring	1	
105	Front Cover Fitting Bolt	12	M16 × 60
106	Rear Cover	1	
107	Rear Cover Fitting Bolt	6	M8 × 20
108	Rear Cover Gasket	1	
109	Eyebolt	2	M10 × 18
113	Gasket	1	
115	Adapter	1	
117	Adapter Fitting Bolt	4	M10 × 35
119	Register Fitting Bolt	4	M6 × 12
121	Iron Slug	1	
122	Spacer	1	
200	Inner Case Assembly	1 set	
※201	First Rotor	1	Signal magnet embedded
※202	Second Rotor	1	
204	Rotor Shaft	2	
206	Thrust Ring A	2	
207	Thrust Ring B	2	
※208	Rotor Bearing	4	
211	O-Ring	2	
221	Shaft Fitting Bolt	8	M8 × 25
222	Shaft Fitting Bolt Washer	8	M8

※: Rotors and rotor bearings are matched pairs and are available as an assembly.

▲: Recommended spare parts.

Symbol No.	Part Name	Q'ty	Remarks
300	Sensor Assembly	1 set	(151 to 158, 160)
151	Sensor Fitting Disc	1	
152	Sensor Retainer	1	
153	Blind Plug	1	
154	O-Ring B	2	S10
155	O-Ring C	1	G65
156	C-shaped Stop Ring	1	
158	Cross Recessed Pan Head Screw	2	M4 × 8 (with washer)
160	Sensor Unit	1	
400 B	Register Assembly	1 set	⇒ See page 54.

12.2 Size 60 Single Construction Meter Exploded View and Parts List

12.2.1 Size 60 Single Construction Meter Exploded View

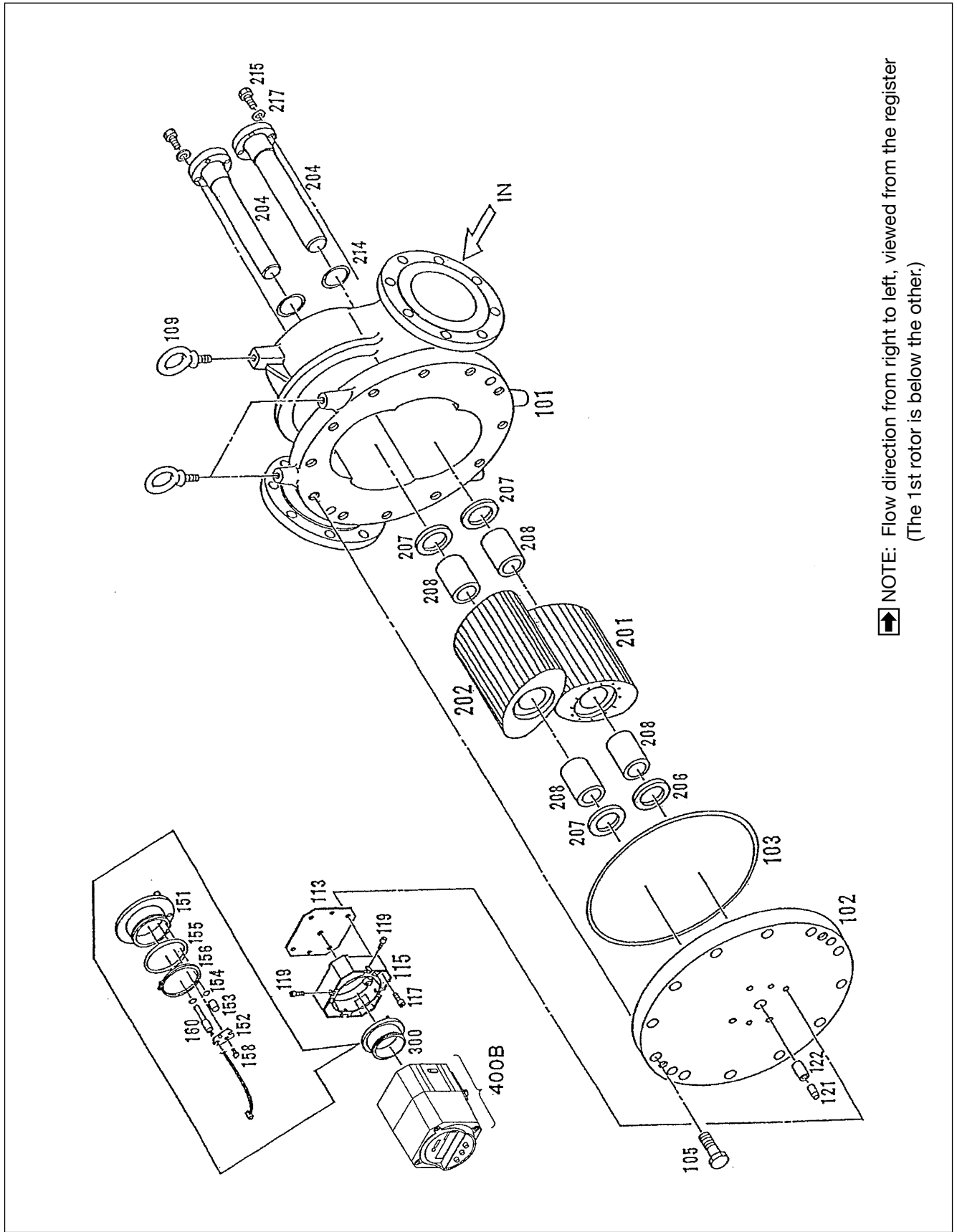

NOTE: See next page for parts list.

12.2.2 Size 60 Single Case Construction Meter Parts List

Symbol No.	Part Name	Q'ty	Remarks
100	Meter Body Assembly	1 set	
101	Meter Body	1	
102	Front Cover	1	
▲ 103	O-Ring	1	JIS P-320
105	Front Cover Fitting Bolt	12	M16 × 60
109	Eyebolt	2	M12
113	Gasket	1	
115	Adapter	1	
117	Adapter Fitting Bolt	4	M10 × 35
119	Register Fitting Bolt	4	M6 × 12
121	Iron Slug	1	
122	Spacer	1	
200	Inner Case Assembly	1 set	
※ 201	First Rotor	1	Signal magnet embedded
※ 202	Second Rotor	1	
204	Rotor Shaft	2	
206	Thrust Ring A	1	
207	Thrust Ring B	3	
※ 208	Rotor Bearing	4	
214	O-Ring	2	JIS S-42
215	Shaft Fitting Bolt	8	M10 × 35
217	Shaft Fitting Bolt Washer	8	M10

Symbol No.	Part Name	Q'ty	Remarks
300	Sensor Assembly	1 set	(151 to 158, 160)
151	Sensor Fitting Disc	1	
152	Sensor Retainer	1	
153	Blind Plug	1	
154	O-Ring B	2	S10
155	O-Ring C	1	G65
156	C-shaped Stop Ring	1	
158	Cross Recessed Pan Head Screw	2	M4 × 8 (with washer)
160	Sensor Unit	1	
400 B	Register Assembly	1 set	⇒See page 54.

※: Rotors and rotor bearings are matched pairs and are available as an assembly.

▲: Recommended spare parts.

12.3 Size 31 Single Case Construction Meter Exploded View and Parts List

12.3.1 Size 31 Single Case Construction Meter Exploded View

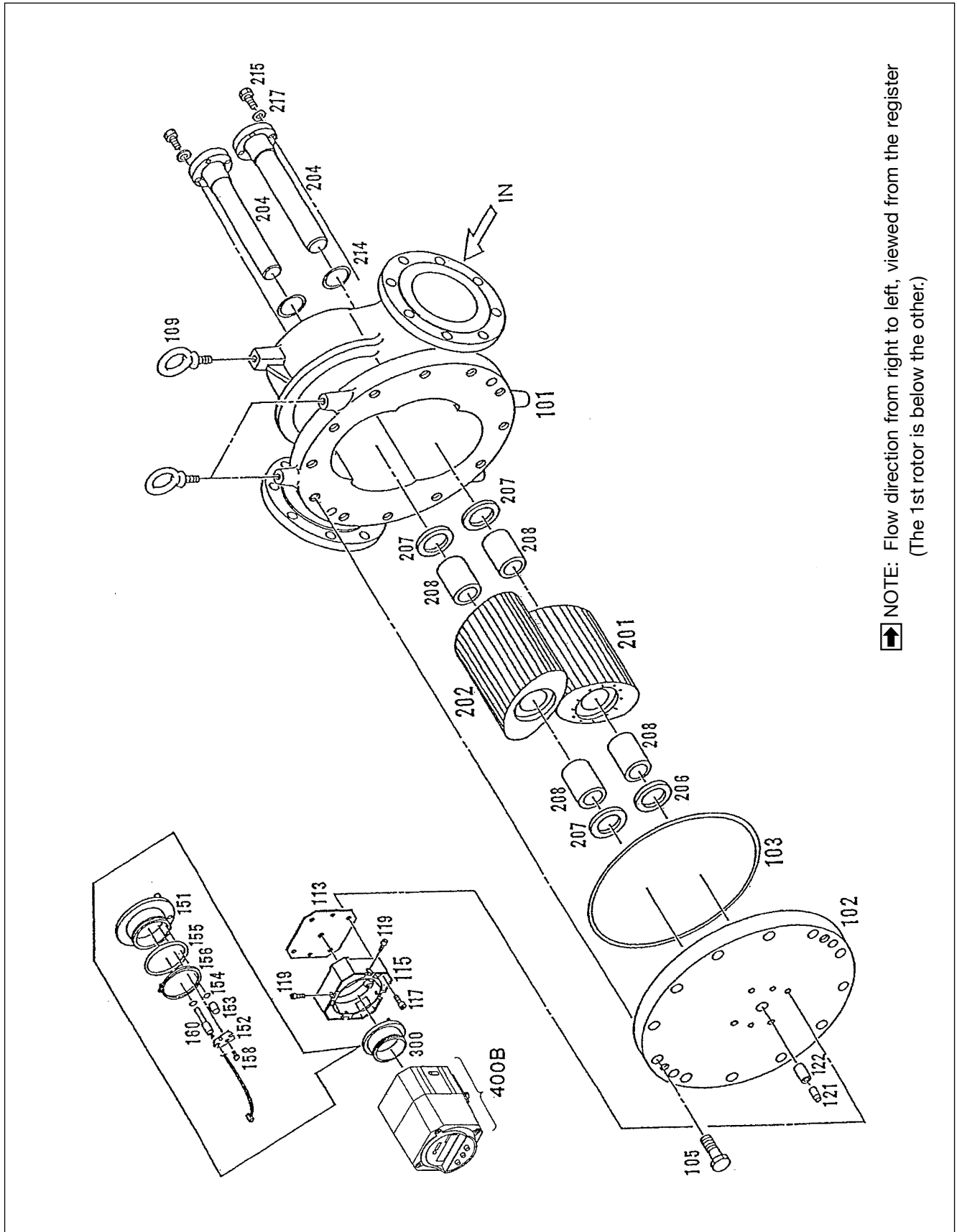

NOTE: See next page for parts list.

12.3.2 Size 31 Single Case Construction Meter Parts List

Symbol No.	Part Name	Q'ty	Remarks
100	Meter Body Assembly	1 set	
101	Meter Body	1	
102	Front Cover	1	
▲ 103	O-Ring	1	JIS P-400
105	Front Cover Fitting Bolt	12	M24 × 75
109	Eyebolt	2	M12
113	Gasket	1	
115	Adapter	1	
117	Adapter Fitting Bolt	4	M10 × 35
119	Register Fitting Bolt	4	M6 × 12
121	Iron Slug	1	
122	Spacer	1	
200	Inner Case Assembly	1 set	
※ 201	First Rotor	1	Signal magnet embedded
※ 202	Second Rotor	1	
204	Rotor Shaft	2	
206	Thrust Ring	4	
※ 208	Rotor Bearing	4	
214	Keystone Ring	2	
215	Blind Cover	2	
217	Blind Cover Fitting Bolt	8	M10 × 35

Symbol No.	Part Name	Q'ty	Remarks
300	Sensor Assembly	1 set	(151 to 158, 160)
151	Sensor Fitting Disc	1	
152	Sensor Retainer	1	
153	Blind Plug	1	
154	O-Ring B	2	S10
155	O-Ring C	1	G65
156	C-shaped Stop Ring	1	
158	Cross Recessed Pan Head Screw	2	M4 × 8 (with washer)
160	Sensor Unit	1	
400 B	Register Assembly	1 set	⇒See page 54.

※: Rotors and rotor bearings are matched pairs and are available as an assembly.

▲: Recommended spare parts.

12.4 Sizes 28, 29, and 31 Double Case Construction Meter, 10K type Exploded View and Parts List

12.4.1 Sizes 28, 29, and 31 Double Case Construction Meter, 10K type Exploded View

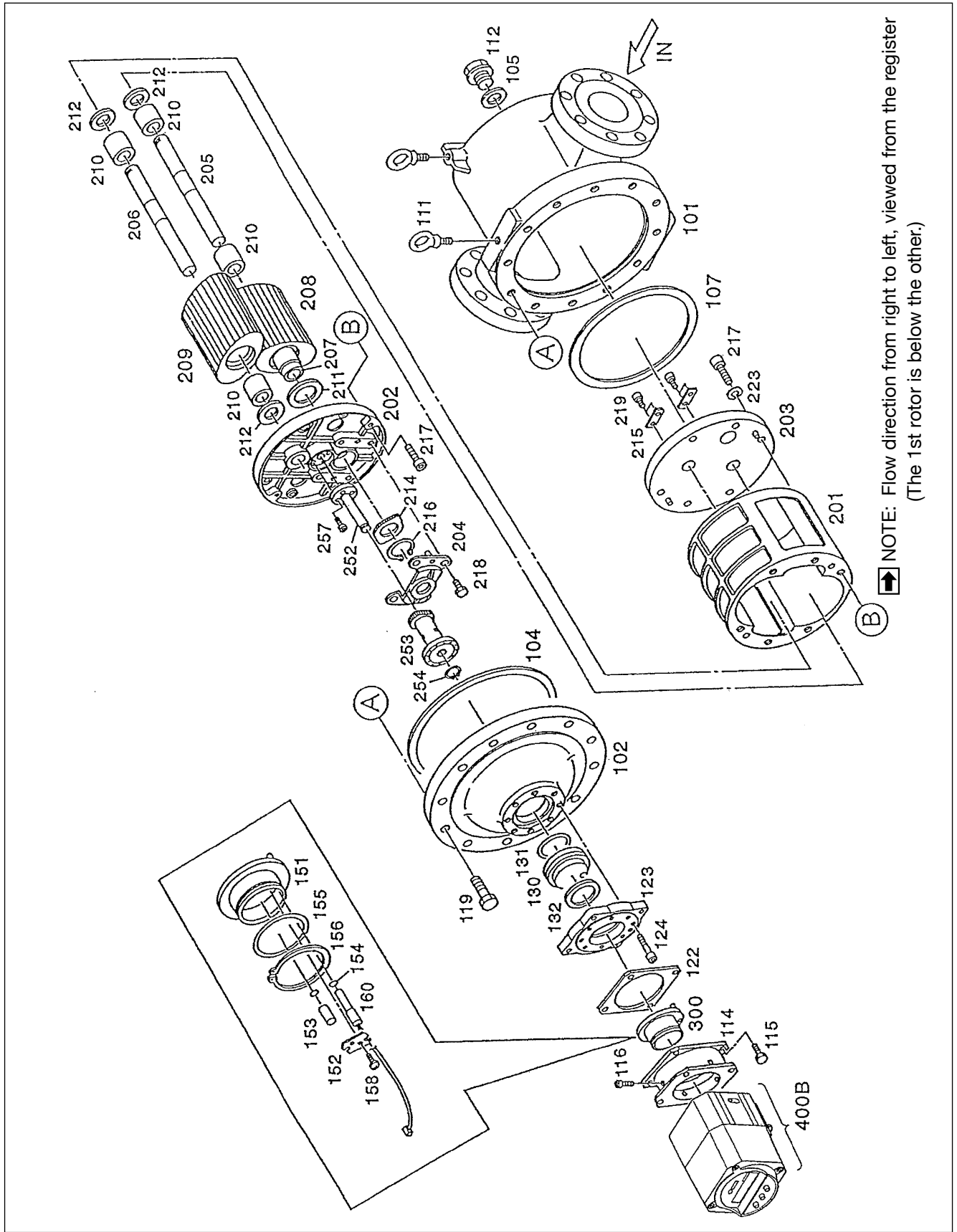

NOTE: See next page for parts list.

12.4.2 Sizes 28, 29, and 31 Double Case Construction Meter, 10K Type Parts List

Symbol No.	Part Name	Size 28		Size 29		Size 31	
		Q'ty	Remarks	Q'ty	Remarks	Q'ty	Remarks
100	Outer Case Assembly	1 set		1 set		1 set	
101	Outer Case	1		1		1	
102	Front Cover	1		1		1	
▲104	Gasket, Outer Case Top Cover	1		1		1	
105	Blind Hole Gasket	1		1		1	
107	Gasket, Inner Case Bottom Cover	1		1		1	
111	Eyebolt	2	M10	1	M10	1	M10
112	Blind Plug	1		1		1	G1
114	Adapter	1		1		1	
115	Adapter Fitting Bolt	4	M10 × 20	4	M10 × 20	4	M10 × 20
116	Register Fitting Bolt	4	M6 × 12	4	M6 × 12	4	M6 × 12
119	Outer Case Top Cover Fitting Bolt	12	M16 × 65	12	M16 × 65	16	M16 × 60
122	Gasket	1		1		1	
123	Sealing Flange	1		1		1	
124	Hex Socket Head Bolt	8	M10 × 45	8	M10 × 45	8	M10 × 45
130	Sealing Plate	1		1		1	
▲131	O-Ring	1		1		1	
132	Sealing Plate Gasket	1		1		1	
200	Inner Case Assembly	1 set		1 set		1 set	
201	Inner Case	1		1		1	
202	Inner Case Top Cover	1		1		1	
203	inner Case Bottom Cover	1		1		1	
204	Longer Shaft Holder	1		1		1	
205	First Rotor Shaft	1		1		1	
206	Second Rotor Shaft	1		1		1	
207	Uniform-motion Gear Boss	1		1		1	
※208	First Rotor	1		1		2	
※209	Second Rotor	1		1		-	---
※210	Rotor Bearing	4		4		4	
211	Thrust Ring A	1		1		1	
212	Thrust Ring B	3		3		3	
214	Uniform-motion Drive Gear	1		1		1	
215	Shaft Non-turn Strip	2		2		2	
216	Stop Ring	1		1		1	
217	Inner Case Top/Bottom Cover Fitting Bolt	12	M12 × 35	12	M12 × 35	12	M12 × 35
218	Longer Shaft Holder Fitting Bolt	4		4		4	M10 × 25
219	Shaft Non-turn Strip Fitting Screw	4		4		4	
223	Spring Washer	6	M12	6	M12	6	M12
252	Signal Magnet Shaft	1		1		1	
253	Signal Generating Magnet Assembly	1 set		1 set		1 set	
254	Stop Ring	1	C14	1	C14	1	C14
257	Signal Magnet Shaft Fitting Bolt	4	M5	4	M5	4	M5
300	Sensor Assembly	1 set	(151 to 158, 160)				
151	Sensor Fitting Bracket	1					
152	Sensor Retainer	1					
153	Blind Plug	1					
154	O-Ring B	2	S10				
155	O-Ring C	1	G65				
156	C-shaped Stop Ring	1					
158	Cross Recessed Pan Head Screw	2	M4 × 8 (with washer)				
160	Sensor Unit	1					
400 B	Register Assembly	1 set	⇒See page 54				

※: Rotors and rotor bearings are matched pairs and are available as an assembly.

▲: Recommended spare parts.

12.5 Size 60 Double Case Construction Meter, 10K type Exploded View and Parts List

12.5.1 Size 60 Double Case Construction Meter, 10K type Exploded View

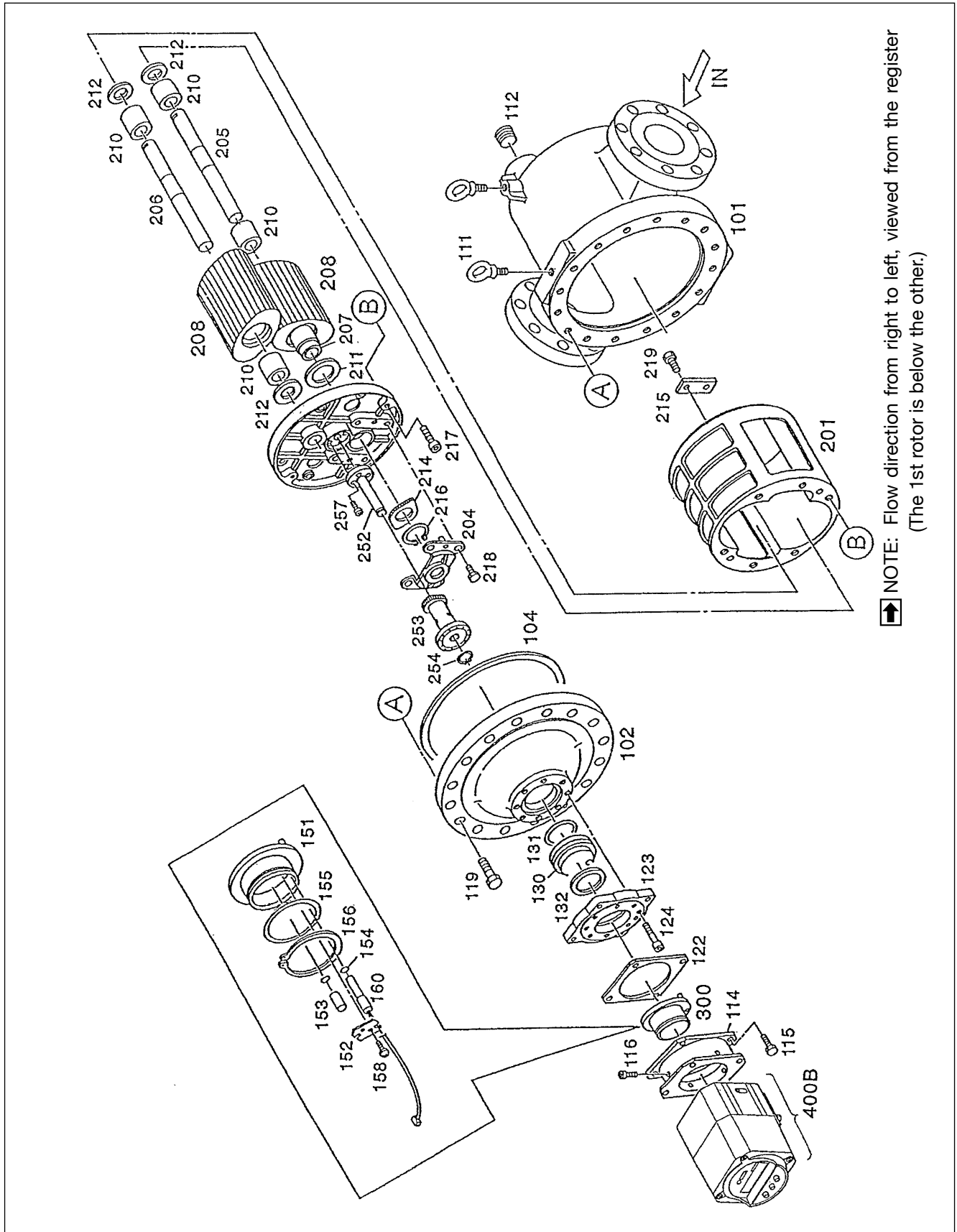

➡ NOTE: Flow direction from right to left, viewed from the register
(The 1st rotor is below the other.)

➡ NOTE: See next page for parts list.

12.5.2 Size 60 Double Case Construction Meter, 10K Type Parts List

Symbol No.	Part Name	Q'ty	Remarks
100	Outer Case Assembly	1 set	
101	Outer Case	1	
102	Front Cover	1	
▲ 104	Gasket	1	
111	Eyebolt	2	
112	Blind Plug	2	R1
114	Adapter	1	
115	Adapter Fitting Bolt	4	M10 × 20
116	Register Fitting Bolt	4	M6 × 12
119	Front Cover Fitting Bolt	16	M16 × 65
122	Gasket	1	
123	Sealing Flange	1	
124	Hex Socket Head Bolt	8	M10
130	Sealing Plate	1	
▲ 131	O-Ring	1	
132	Sealing Plate Gasket	1	
200	Inner Case Assembly	1 set	
201	Inner Case	1	
202	End Plate	1	
204	Major Axis Holder	1	
205	First Rotor Shaft	1	
206	Second Rotor Shaft	1	
207	Uniform-motion Gear Boss	1	
※ 208	Rotor	2	
※ 210	Rotor Bearing	4	
211	Thrust Ring A	1	
212	Thrust Ring B	3	
214	Uniform-motion Drive Gear	1	
215	Shaft Non-turn Strip	1	
216	Stop Ring	1	C42
217	End Plate Fitting Bolt	4	M12 × 45
218	Major Axis Holder Fitting Bolt	4	M10 × 20
219	Shaft Non-turn Strip Fitting Screw	2	M10 × 15
252	Signal Magnet Shaft	1	
253	Signal Generating Magnet Assembly	1 set	
254	Stop Ring	1	
257	Signal Magnet Shaft Fitting Bolt	4	M5

Symbol No.	Part Name	Q'ty	Remarks
300	Sensor Assembly	1 set	(151 to 158, 160)
151	Sensor Fitting Bracket	1	
152	Sensor Retainer	1	
153	Blind Plug	1	
154	O-Ring B	2	S10
155	O-Ring C	1	G65
156	C-shaped Stop Ring	1	
158	Cross Recessed Pan Head Screw	2	M4 × 8 (with washer)
160	Sensor Unit	1	
400 B	Register Assembly	1 set	⇒See page 54.

※: Rotors and rotor bearings are matched pairs and are available as an assembly.

▲: Recommended spare parts.

12.6 Sizes 28, 29, and 31 Double Case Construction Meter, 30K type (F3) Exploded View and Parts List

12.6.1 Sizes 28, 29, and 31 Double Case Construction Meter, 30K type (F3) Exploded View

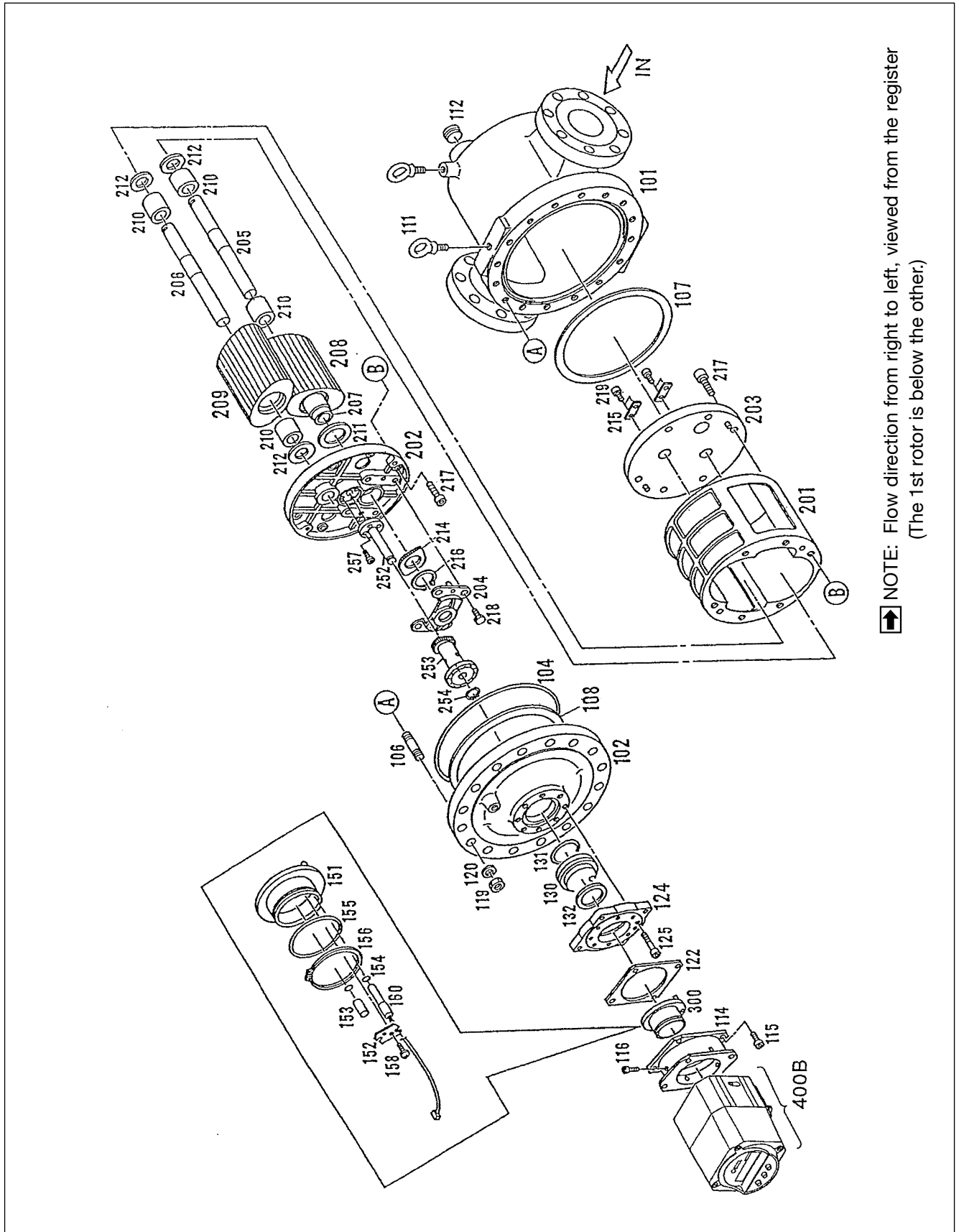

➡ NOTE: Flow direction from right to left, viewed from the register
(The 1st rotor is below the other.)

➡ NOTE: See next page for parts list.

12.6.2 Sizes 28, 29, and 31 Double Case Construction Meter, 30K Type (F3) Parts List

Symbol No.	Part Name	Q'ty	Remarks	Symbol No.	Part Name	Q'ty	Remarks
100	Outer Case Assembly	1 set		300	Sensor Assembly	1 set	(151 to 158, 160)
101	Outer Case	1		151	Sensor Fitting Bracket	1	
102	Front Cover	1		152	Sensor Retainer	1	
▲ 104	O-Ring	1		153	Blind Plug	1	
106	Stud Bolt	16		154	O-Ring B	2	S10
107	Gasket, Inner Case Bottom	1		155	O-Ring C	1	G65
108	Gasket, Inner Case Top	1		156	C-shaped Stop Ring	1	
111	Eyebolt	2		158	Cross Recessed Pan Head Screw	2	M4 x 8 (with washer)
112	Blind Plug	2	R1	160	Sensor Unit	1	
114	Adapter	1		400 B	Register Assembly	1 set	⇒See page 54.
115	Adapter Fitting Bolt	4					
116	Register Fitting Bolt	4	M6				
119	Nut	16					
120	Washer	16					
122	Gasket	1					
124	Sealing Flange	1					
125	Hex Socket Head Bolt	8	M10				
130	Sealing Plate	1					
▲ 131	O-Ring	1					
132	Sealing Plate Gasket	1					
200	Inner Case Assembly	1 set					
201	Inner Case	1					
202	Inner Case Top Cover	1					
203	Inner Case Bottom Cover	1					
204	Longer Shaft Holder	1					
205	First Rotor Shaft	1					
206	Second Rotor Shaft	1					
207	Uniform-motion Gear Boss	1					
※ 208	First Rotor	1					
※ 209	Second Rotor	1					
※ 210	Rotor Bearing	4					
211	Thrust Ring A	1					
212	Thrust Ring B	3					
214	Uniform-motion Drive Gear	1					
215	Shaft Non-turn Strip	2					
216	Stop Ring	1	C35				
217	Inner Case Top/Bottom Cover Fitting Bolt	12					
218	Longer Shaft Holder Fitting Bolt	4					
219	Shaft Non-turn Strip Fitting Screw	4	M4				
252	Signal Magnet Shaft	1					
253	Signal Generating Magnet Assembly	1 set					
254	Stop Ring	1					
257	Signal Magnet Shaft Fitting Bolt	4	M5				

※: Rotors and rotor bearings are matched pairs and are available as an assembly.

▲: Recommended spare parts.

12.7 Size 60 Double Case Construction Meter, 30K type (F3) Exploded View and Parts List

12.7.1 Size 60 Double Case Construction Meter, 30K type (F3) Exploded View

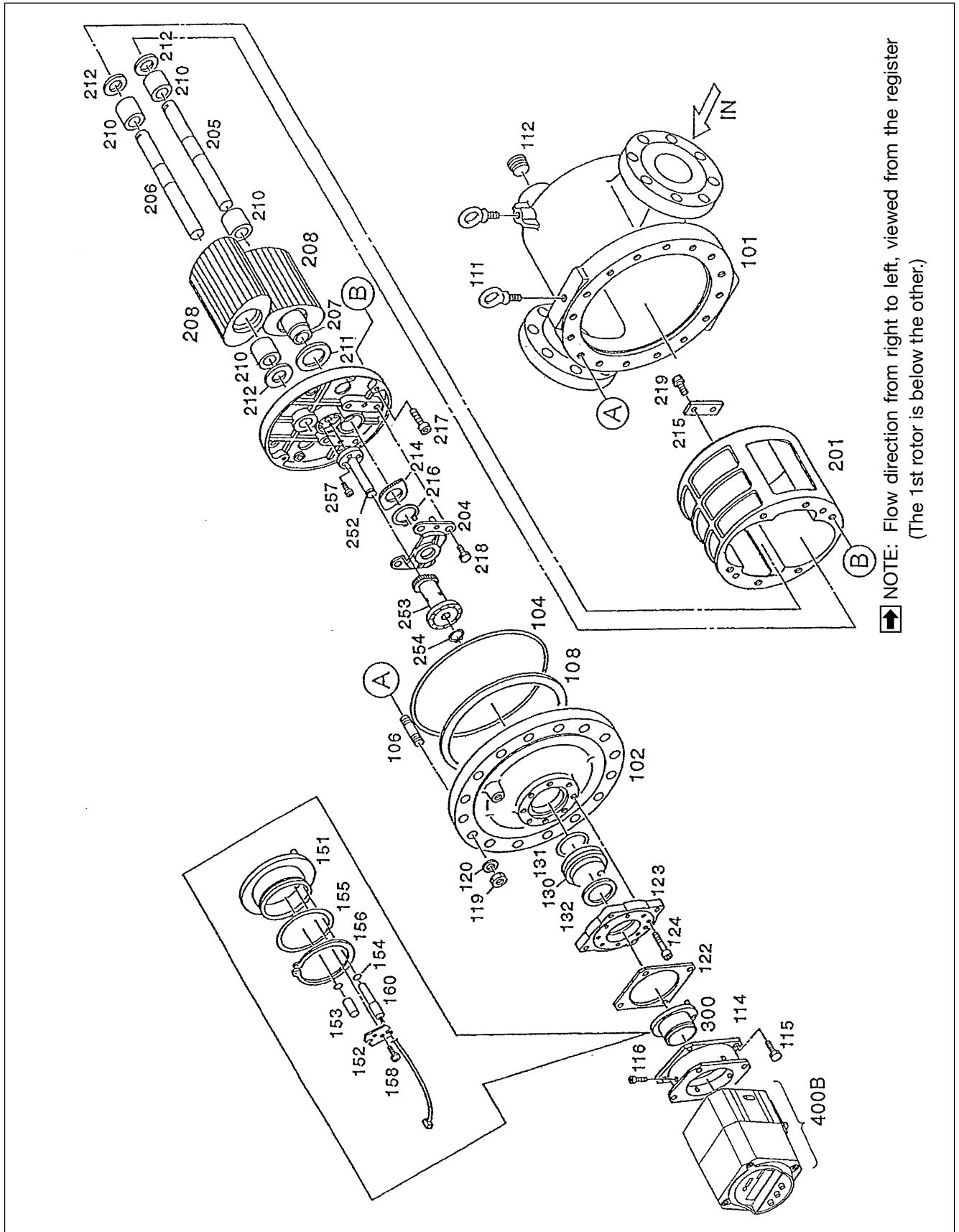

NOTE: See next page for parts list.

12.7.2 Size 60 Double Case Construction Meter, 30K Type (F3) Parts List

Symbol No.	Part Name	Q'ty	Remarks
100	Outer Case Assembly	1 set	
101	Outer Case	1	
102	Front Cover	1	
▲ 104	O-Ring	1	P320
106	Stud Bolt	16	M20 × 95
108	Gasket, Inner Case Bottom	1	
111	Eyebolt	2	M12 × 22
112	Blind Plug	2	R1
114	Adapter	1	
115	Adapter Fitting Bolt	4	M10 × 20
116	Register Fitting Bolt	4	M6 × 12
119	Nut	16	M20
120	Washer	16	M20
122	Gasket	1	
123	Sealing Flange	1	
124	Hex Socket Head Bolt	8	M10
130	Sealing Plate	1	
▲ 131	O-Ring	1	
132	Sealing Plate Gasket	1	
200	Inner Case Assembly	1 set	
201	Inner Case	1	
202	Inner Case Top Cover	1	
204	Inner Case Bottom Cover	1	
205	Longer Shaft Holder	1	
206	First Rotor Shaft	1	
207	Second Rotor Shaft	1	
※ 208	Uniform-motion Gear Boss	2	
※ 210	First Rotor	4	
211	Second Rotor	1	
212	Rotor Bearing	3	
214	Thrust Ring A	1	
215	Thrust Ring B	1	
216	Uniform-motion Drive Gear	1	C42
217	Shaft Non-turn Strip	4	M12 × 45
218	Stop Ring	4	M10 × 20
219	Inner Case Top/Bottom Cover Fitting Bolt	2	M10 × 15
252	Longer Shaft Holder Fitting Bolt	1	
253	Shaft Non-turn Strip Fitting Screw	1 set	
254	Stop Ring	1	
257	Inner Case Top/Bottom Cover Fitting Bolt	4	M5

Symbol No.	Part Name	Q'ty	Remarks
300	Sensor Assembly	1 set	(151 to 158, 160)
151	Sensor Fitting Bracket	1	
152	Sensor Retainer	1	
153	Blind Plug	1	
154	O-Ring B	2	S10
155	O-Ring C	1	G65
156	C-shaped Stop Ring	1	
158	Cross Recessed Pan Head Screw	2	M4 × 8 (with washer)
160	Sensor Unit	1	
400 B	Register Assembly	1 set	⇒See page 54.

※: Rotors and rotor bearings are matched pairs and are available as an assembly.

▲: Recommended spare parts.

12.8 Register Exploded View and Parts List

● When you order replacement parts, specify the stock No., flowmeter model, instruction manual No., symbol No., part name and the quantity desired.

◇EXPLODED VIEW◇

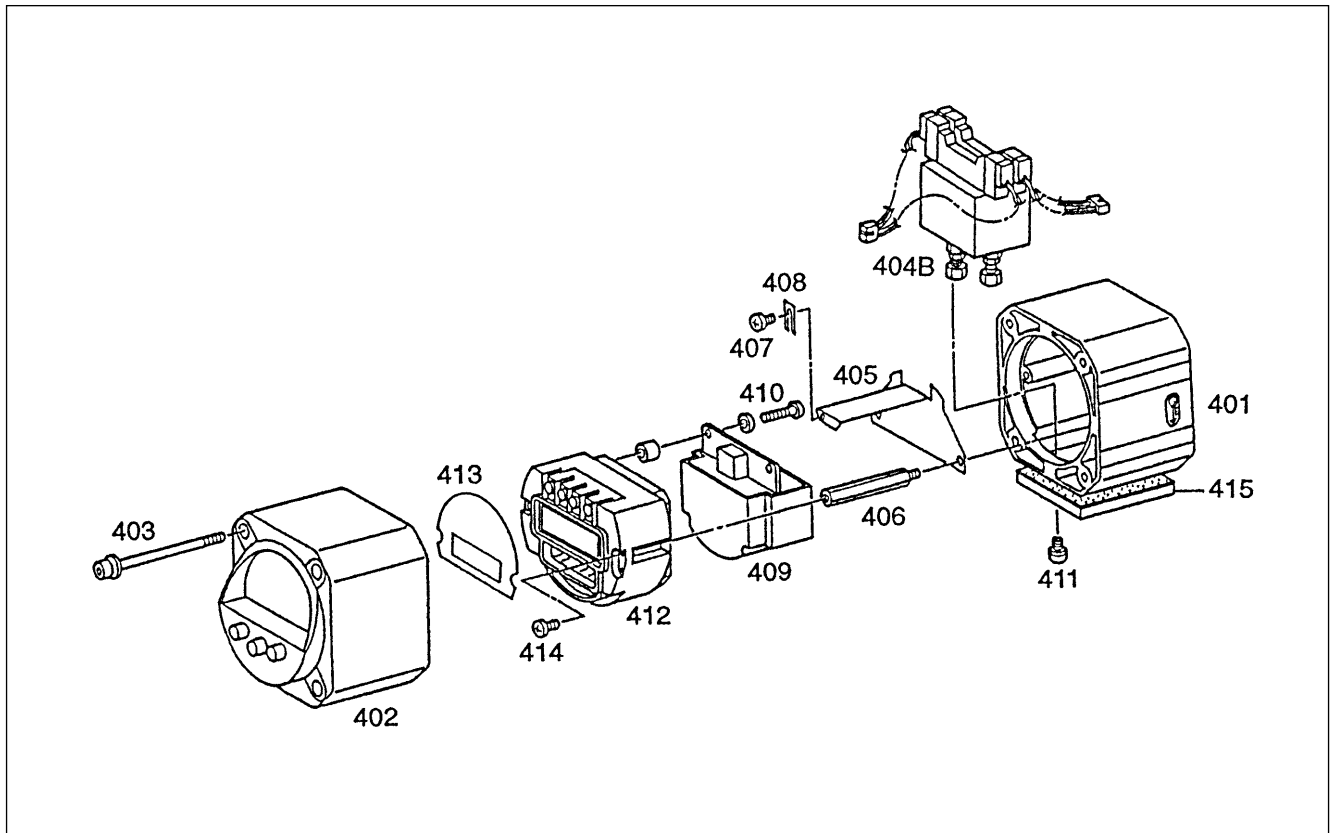

◇PARTS LIST◇

Symbol No.	Part Name	Q'ty	Remarks
400 B	LW74E Register Assembly	1 set	(401 to 415)
401	Register Body	1	
402	Register Front Cover	1	with pushbuttons
403	Fitting Bolt, Front Cover	4	M6 with washer
404 B	Solenoid Valve Assembly	1	for LW76E register
405	Retainer	1	
406	Hex Strut	2	M4
407	Retaining Setscrew	1	
408	Hold-down Strip	1	
▲ 409	Battery Pack	1	
410	Battery Pack Fitting Screw	5	M3
411	Solenoid Valve Fitting Bolt	8	M4 with washer
412	Internal Assembly	1	
413	Faceplate	1	
414	Internal Ass'y Fitting Screw	2	M4 with washer
415	Hold-down Base	1	with packing

▲: Recommended spare parts.

13. GENERAL SPECIFICATIONS

● Register Assembly

ITEM		DESCRIPTION		
		LW76E		
Pneumatic Circuit	Type of control	Air two-step open, two-step close (One-step open mode available by setting the initial value at 0.)		
	Signal air pressure	0.20 to 0.69MPa (depends on the shutoff valve rating.) (Air must be clean and dry.)		
	Air signal line connection	Rc 1/8 with a bite-type fitting for $\phi 6 \times \phi 4$ copper tubing provided		
	Distance to the shutoff valve	3 meters max.		
Display	Batch setpoint or accumulated total readout (selectable with front pushbuttons)	Batch setpoint	6-digit, 7-segment LCD except for the 1st and 8th digit	
		Accum. total	8-digit, 7-segment LCD (characters 12.7mm high)	
	Counting unit	Meter Size	Standard	Option
		28	$\times 0.1L$	$\times 1L, \times 10L$
		29	$\times 1L$	$\times 10L$
	60, 31	$\times 1L$	$\times 10L, \times 100L$	
	Operation status indicators		Shows in the 1st and 8th digit of the LCD only in the batch setpoint readout. RUN: Blinks while in operation OUT: Lights up while valve operating signal is being output ALM: Lights to indicate missing pulses, or exceeding a preset overshoot, etc. COUNT: Lights up while the totalizer counts END: Lights up upon completion of a batch cycle	
Low battery alarm		Front-panel LCD "BATT" lights up when the battery life has approached.		
Setup	Type of operation		Select either add or subtract mode (subtract mode is standard).	
	Operation and programming		STOP, RESET, START manually with three front-panel pushbuttons. Batch setpoint (6 digits) - Can be changed in the RUN mode. Cumulative total reading (8 digits) - Can be changed In the SET mode	
	Initial setting (oP) and final setting (cL)		Set to any point from 0 to 999 counts in the SET mode. (A setpoint at 0 makes the one-step open, one-step close mode.)	
	Missing pulse setting (PL)		Set to any point from 0 to 15 sec. in the SET mode. (A setpoint at 0 disables the missing pulse setting.)	
	Overshoot setup (oV)		Set to any point from 0 to 99 counts in the SET mode. (A setpoint at 0 disables the overshoot setting.)	
	Scaler setup	Coefficient (F)	Set to any point from 0.0001 to 1.9999 in the SET mode	
Frequency divide (d)		Selectable from one of 1/1, 1/10, and 1/100 in the SET mode		
Repeat feature		Provided		
Emergency stop		By front pushbutton (STOP). Can resume measurement for the remaining cycle.		
Backup feature		Retains parameters, batch setpoint, total reading, cumulative total in an EEPROM.		
Power source		Dedicated battery (4 years approx., though, depending on operating conditions.)		
Waterproof construction		JIS C 0920 weatherproof (IP65)		
Explosionproof construction		Select one of the following two: (1) Nonexplosionproof (2) Intrinsically safe explosionproof: Exia II BT3 1) TIIS Explosionproof (Battery powered) 2) NEPSI Explosionproof (Battery powered)		
Ambient Temperature Range		-10 to +60°C (Valve actuating fluid must not contain drain or mist at low temperatures.)		
External finish		Munsell 2.5PB 5/8 (finished in baked melamine)		
Enclosure material		Aluminum die casting		
Physical orientation		Horizontal or vertical (view angle is adjustable)		
Option		Air set (one set) includes a mist separator, combination filter/reducing valve, etc.		

● Nominal Meter Factors

➡ NOTE: At standard temp.

Size	Number of Pulses, P/r	Nominal Meter Factor, L/P	Cycle Sample Number
28	12	0.13516	24
29	12	0.19863	
60	12	0.3389	
31	12	0.6295	

NOTE: For outline dimensions and pipeline connection dimensions, see the approval drawing (or specifications of the product).